

Mark 86 Series

Steam Tracing Temperature Regulators

The Mark 86 ambitemp regulator is designed to control steam tracing lines based on ambient temperatures. These steam tracing lines are commonly used to protect outdoor instrumentation, pipelines and tanks from freezing. The Mark 86 allows steam to flow through the tracer lines only when it is needed, and remains closed when the ambient temperature rises above a predetermined set point.

SEALED WELDED ACTUATOR (SWA)

The Mark 86, like our other self-acting temperature regulators, utilizes both Jordan's sliding gate seat design and Jordan's seal-welded actuator. The sealed welded actuator (SWA) has no elastomer parts, and is utilized for its ability to provide longer lasting service. With all steel construction, there are no parts that will wear out from temperature effects. Although it is made with the same materials and design, the SWA on the Mark 86 is different from our standard sealed welded actuator. Our Jordan temperature regulators have an SWA that consists of bulb, capillary and diaphragm assembly. As the ambitemp valve is only sensing the ambient temperature, the sensing bulb and capillary are eliminated from the construction.

The Mark 86 is generally installed as a normally closed valve. As the ambient temperature falls below the set point, the valve will open, allowing steam to enter the tracing line system. The Mark 86 may also be set up as a normally open valve and stroke toward closed as the ambient temperature rises.

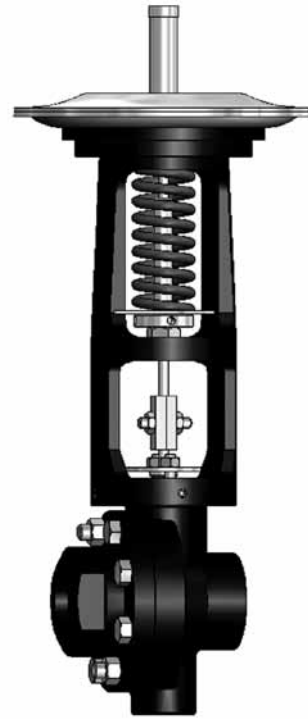

FEATURES

- Sealed Welded Actuator – no elastomer parts providing longer service life
- Sliding Gate Seats – features advanced sliding gate seat technology
 - Straight-through flow for reduced turbulence and quiet operation
 - Short stroke for fast response and accurate regulation
 - Easily interchangeable Cv's
 - Tight shutoff



Jordan Valve a division of Richards Industries
3170 Wasson Road • Cincinnati, OH 45209
513.533.5600 • 800.543.7311 • 513.871.0105 (f)
info@richardsind.com • www.jordanvalve.com

SPECIFICATIONS

Sizes: 1/2" (DN15) through 2" (DN50)

End Connections

- Threaded – FNPT, BSPT, BSPP
- ANSI Flanges – 150#, 300#
- DIN Flanges – PN 10/16, PN 25/40
- JIS Flanges – 10K, 20K

Body Materials

- Ductile Iron
- Bronze
- Carbon Steel
- Stainless Steel

Trim Materials

- 303SS for DI, BRZ & CS body valves
- 316SS for SS body valves

Seat Materials

- Jorcote on SST – Standard
- Jorcote/Jordanic on SST – For severe service
- Chrome Plated SST – Optional

Yoke Material: Cast Iron

Stem Packing Materials

- Spring-loaded Teflon (up to 500°F, 260°C max)
- Braided (above 500°F/260°C)

Service: Steam, water, oil, gas, air and chemicals

Shutoff: ANSI Class IV

Action

- Direct (increase in temperature closes valve)
- Reverse (increase in temperature opens valve)

Body Rating: Ductile Iron up to 988 psi (68,1 bar) and 650°F (343,3°C); Carbon Steel and Stainless Steel up to 1480 psi (102 bar) and 650°F (343,3°C); Bronze up to 500 psi (34,5 bar) and 500°F (260°C) depending on specific construction. -20°F (28,9°C) temperature limit on all materials; for other temperatures, consult factory

Overheat Protection: 100°F (38°C) above top of control range

Cv (Kv) Values & Maximum Differential Pressures:

Valve Size		Flow Coefficient		Seat Material	Max ΔP	
Inches	DN	Cv	Kv		PSI	Bar
1/2" or 3/4"	15 or 20	2.5 or 4.4	2,2 or 3,8	SST	125	8,6
				Jorcote	300	20,7
1" or 1-1/4"	25 or 32	6.4 or 9.5	5,5 or 8,2	SST	125	8,6
				Jorcote	250	17,2
1-1/2"	40	15	12,9	SST	75	5,2
				Jorcote	175	12,1
2"	50	25 or 30	21,5 or 25,8	SST	75	5,2
				Jorcote	175	12,1

Low Flow Cv's (Kv's) Available: reduced Cv's (Kv's) can be used in a valve of any size as long as the required Cv (Kv) is a smaller value than the standard for that particular size. In addition, the following Cv (Kv) values can be provided:

1.6 (1,4)	0.8 (0,7)	0.4 (0,4)	0,2 (0,18)	0.08 (0,07)	0.04 (0,03)
0.02 (0,017)	0.008 (0,007)	0.004 (0,003)	0.002 (0,0017)	0.0008 (0,0007) (N/A in 316SS)	

Available Temperature Control Ranges & Spans

- Standard Spring #37

Temperature Control Ranges, °F (°C)			
5 to 40 (-15 to 4,4)	30 to 80 (-1 to 27)	50 to 100 (10 to 38)	80 to 130 (27 to 54)
100 to 150 (38 to 66)	115 to 170 (46 to 77)	155 to 210 (68 to 99)	
Valve Size	Temperature span from closed to open, °F (°C)		
1/4" to 3/4" (DN8 to DN20)	10 (6)		
1" to 1-1/4" (DN25 to DN32)	15 (8)		
1-1/2" to 2" (DN40 to DN50)	20 (11)		

Note: consult factory for spans on ranges 115 - 170°F (64 - 95°C) and 155 - 210°F (86 - 117°C)

- Light Spring #152

Temperature Control Ranges, °F (°C)			
0 to 20 (-18 to -7)	25 to 60 (-4 to 16)	45 to 80 (7 to 27)	75 to 110 (24 to 43)
100 to 130 (38 to 54)	115 to 150 (46 to 66)	155 to 190 (68 to 88)	
Valve Size	Temperature span from closed to open, °F (°C)		
1/4" to 3/4" (DN8 to DN20)	6 (3)		
1" to 1-1/4" (DN25 to DN32)	10 (6)		
1-1/2" to 2" (DN40 to DN50)	13 (7)		

Note: consult factory for spans on ranges 95 - 130°F (53 - 72°C), 115 - 160°F (64 - 89°C), 145 - 180°F (81 - 100°C), and 155 - 190°F (86 - 106°C)

DIMENSIONS

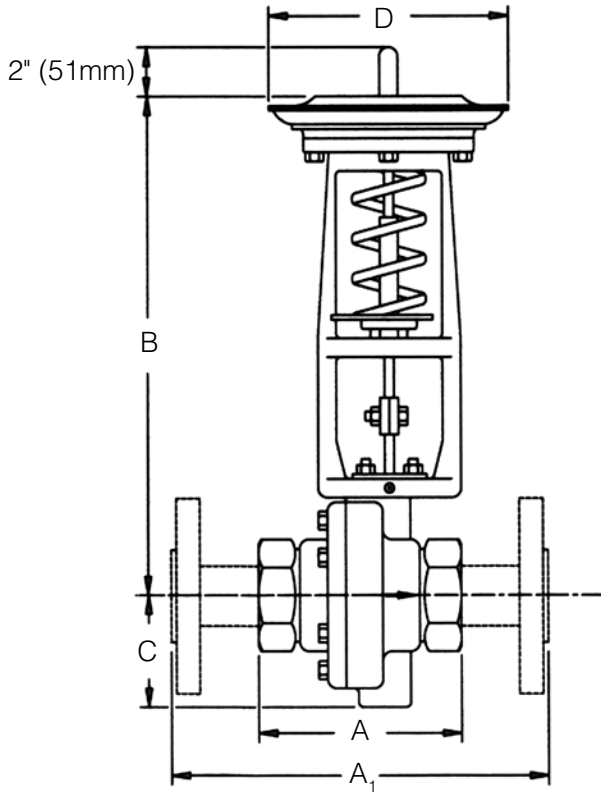

• Flanged Ends

Valve Size	ANSI Flange	Dimensions (Inches)				Weight lbs	
		A ₁	B	C	D	DI/BRZ	CS/SS
1/2"	150#	7.25	12.00	2.18	7.00	21	23
	300#	7.50	12.00	2.18	7.00	22	24
3/4"	150#	7.25	12.00	2.18	7.00	22	25
	300#	7.62	12.00	2.18	7.00	23	28
1"	150#	7.25	12.25	2.62	7.00	24	28
	300#	7.75	12.25	2.62	7.00	25	30
1-1/4"	150#	7.87	12.25	2.62	7.00	25	30
	300#	8.37	12.25	2.62	7.00	26	32
1-1/2"	150#	8.75	12.25	2.75	7.00	27	32
	300#	9.25	12.75	2.75	7.00	30	38
2"	150#	10.00	12.81	3.00	7.00	29	38
	300#	10.50	12.81	3.00	7.00	31	42

• Flanged Ends, DIN

Valve Size	Flange (PN)	Dimensions (Metric)				Weight kgs	
		A ₁	B	C	D	DI/BRZ	CS/SS
DN15	10/16	184,2	304,8	55,4	177,8	9,5	10,5
	25/40	190,5	304,8	55,4	177,8	10	11
DN20	10/16	184,2	304,8	55,4	177,8	10	11
	25/40	193,5	304,8	55,4	177,8	10,5	13
DN25	10/16	184,2	311,2	66,5	177,8	11	13
	25/40	196,9	311,2	66,5	177,8	11	13,5
DN32	10/16	199,9	311,2	66,5	177,8	11	13,5
	25/40	212,6	311,2	66,5	177,8	12	14,5
DN40	10/16	222,3	311,2	69,9	177,8	12	14,5
	25/40	235,0	323,9	69,9	177,8	13,5	17
DN50	10/16	254,0	325,4	76,2	177,8	13	17
	25/40	266,7	325,4	76,2	177,8	14	19

• Threaded & FSW Ends

Valve Size	Material	Dimensions (Inches)				Weight lbs
		A	B	C	D	
1/2" & 3/4"	DI/BRZ	3.62	12.00	2.18	7.00	20
	CS/SS	3.62	12.00	2.18	7.00	21
1"	DI/BRZ	4.12	12.25	2.62	7.00	22
	CS/SS	4.12	12.25	2.62	7.00	23
1-1/4"	DI/BRZ	4.12	12.25	2.62	7.00	22
1-1/2"	DI/BRZ	4.50	12.75	2.75	7.00	24
	CS/SS	4.65	12.75	2.75	7.00	25
2"	DI/BRZ	4.50	12.81	3.00	7.00	24
	CS/SS	5.50	12.81	3.00	7.00	27

• Threaded & FSW Ends, DIN

Valve Size	Material	Dimensions (Metric)				Weight kgs
		A	B	C	D	
DN15, DN20	DI/BRZ	91,9	304,8	55,4	178	9
	CS/SS	91,9	304,8	55,4	178	9,5
DN25	DI/BRZ	104,6	311,2	66,5	178	10
	CS/SS	104,6	311,2	66,5	178	10,5
DN32	DI/BRZ	104,6	311,2	66,5	178	10
DN40	DI/BRZ	114,3	323,9	69,9	178	11
	CS/SS	118,1	323,9	69,9	178	11
DN50	DI/BRZ	114,3	325,4	76,2	178	11
	CS/SS	139,7	325,4	76,2	178	12

ORDERING SCHEMATIC

Model No	Size	Body Mat'l	1	2	3	4	5	6	7	8	9	10	11	12	13	14	15	16

Model	
86	Standard

Size	
025	1/4" (DN8)
038	3/8" (DN10)
050	1/2" (DN15)
075	3/4" (DN20)
100	1" (DN25)
125	1-1/4" (DN32)
150	1-1/2" (DN40)
200	2" (DN50)

Body Material	
DI	Ductile Iron
BR	Bronze
CS	Carbon Steel (WCB)
S6	Stainless Steel (CF8M)

End Connections	
PT	NPT
BT	BSPT
BP	BSPP
SW	FSW
I5	150# IFE CS or SST valves
I3	300# IFE CS or SST valves
I7	IFE PN10 CS or SST valves
I6	IFE PN16 CS or SST valves
I8	IFE PN25 CS or SST valves
I4	IFE PN40 CS or SST valves

Trim	
T3	303SS
T6	316SS
ZZ	Non-standard

Seats			
5 & 6	Material	Cv (Kv)	
A	303 SST	1	0.21 (0.18)
B	316 SST	2	0.42 (0,36)
V	303SS/Jorcote	3	0.84 (0,72)
W	316SS/Jorcote	4	1.6 (1,4)
X	303SS/Jorcote/Jordanic	5	2.5 (2,2)
Y	316SS/Jorcote/Jordanic	6	4.4 (3,8)
		7	6.4 (5,5)
		8	9.5 (8,2)
		9	15.0 (12,9)
		A	25.0 (21,5)
		B	30.0 (25,8)
ZZ	Non-Standard		

Range			
7 & 8			
10	5~40 (-15~4)	09	0~20 (-18~-7)
18	30~80 (-1~27)	15	25~60 (-4~16)
25	50~100 (10~38)	22	45~80 (7~27)
34	80~130 (27~54)	31	75~110 (24~43)
39	100~150 (38~66)	38	100~130 (38~54)
48	115~170 (46~77)	45	115~150 (46~66)
57	155~210 (68~99)	55	155~190 (68~88)
ZZ	Non-Standard		

Thermowell	
9 & 10	
00	None

Bulb	
11 & 12	
00	None

Capillary/Armor	
13 & 14	
00	None

Actuator	
15	
A	Standard

Action	
16	
D	Direct
R	Reverse

