

Mark 695X Series

Tank Blanketing Regulator 1/2"- 3/4"

The Mark 695X Series regulator was designed specifically to provide accurate pressure control on very low pressure tank blanketing systems. The Mark 695X responds to very small changes in tank pressure by throttling open or closed to maintain the desired pressure set point.

- Direct Operated
- Fully Balanced Plug
- Accurate regulation down to 1/2" wc (1.25 mbar)
- ANSI Class VI Shutoff
- Two available spring ranges
- 200 psi maximum inlet pressure
- Three Cv's (Kv's): 0.15, 0.2, 0.4 (0,13, 0,17, 0,35)
- Ultra Lightweight Diaphragm for Maximum Sensitivity

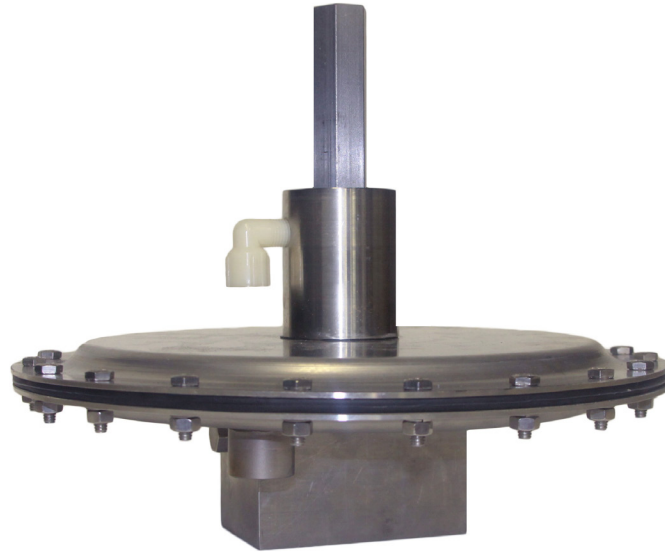

OPTIONAL FEATURES

- Inlet Gauges: 0-100, 0-200
- Purge Feature
- Optional High Alloys Available
- ANSI & DIN Flanged Ends
- Outlet Check Valve



Jordan Valve a division of Richards Industries
3170 Wasson Road • Cincinnati, OH 45209
513.533.5600 • 800.543.7311 • 513.871.0105 (f)
info@richardsind.com • www.jordanvalve.com

SPECIFICATIONS

Sizes:

- 1/2" – 3/4" (DN15 – DN20)

End Connections:

- FNPT
- ANSI & DIN Flanges

Body Materials:

- 316L Stainless Steel
- Other Materials Available on Application

Spring Housing:

- 316L Stainless Steel

Diaphragm:

- Ultra Lightweight Teflon

Seats and Balance Diaphragm:

- Buna-N, FKM, EPDM, Kalrez

Service:

- Tank blanketing

Flow Capacity:

- Cv (Kv): 0.15 (0,13), 0.2 (0,17), 0.4 (0,34)

Shutoff:

- ANSI Class VI (ANSI/FCI 70-3-2016)

Available Spring Ranges

- 0.5 – 5.5 wc (1,25 mb - 13,7 mb)
- 4 – 10 wc (9,96 mb - 24,9 mb)

Max Operating Inlet Pressure:

- 200 psig @ 100°F (13,8 barg @ 38°C)

Max Differential Pressure:

- 200 psig @ 100°F (13,8 barg @ 38°C)

Max Downstream Pressure (Safety Rating):

- 20 psig (1,38 barg)

Operating Temperatures:

- Determined by Elastomer

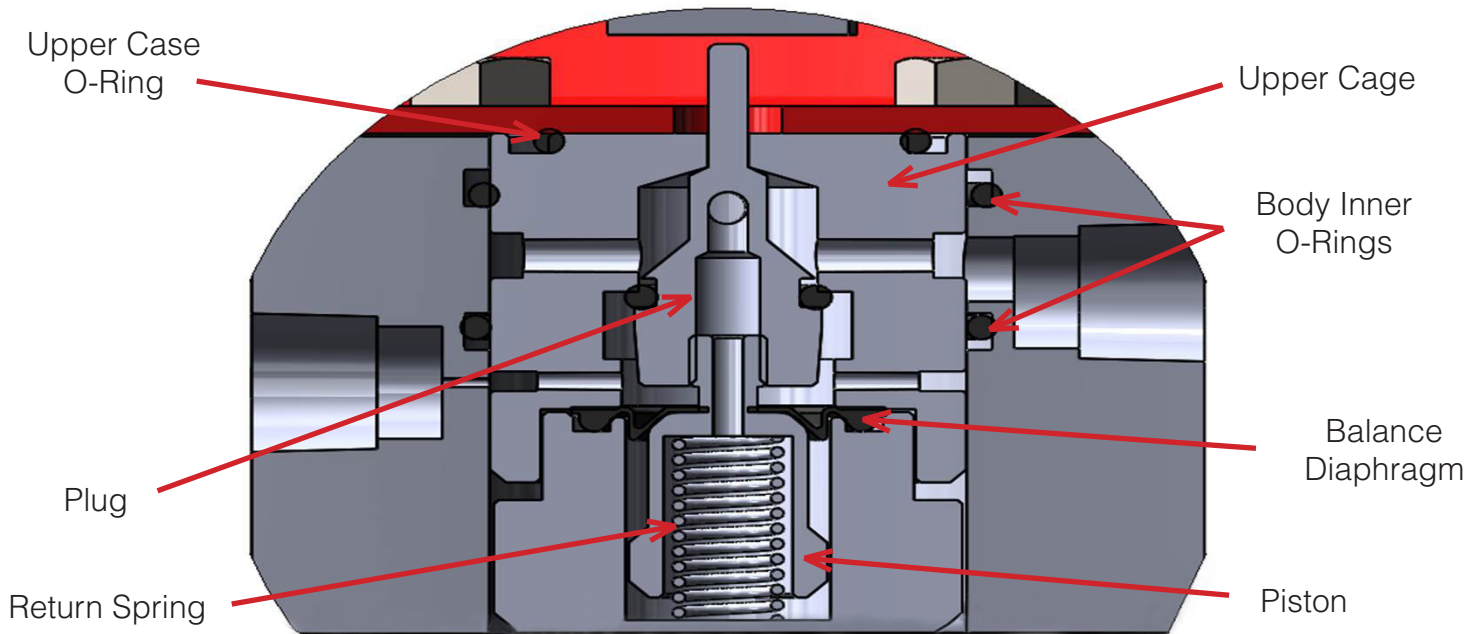

Plug Assembly

DIMENSIONS

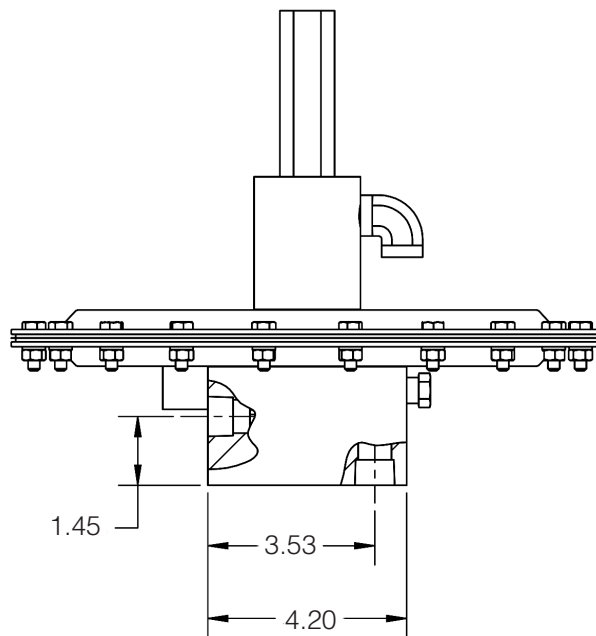
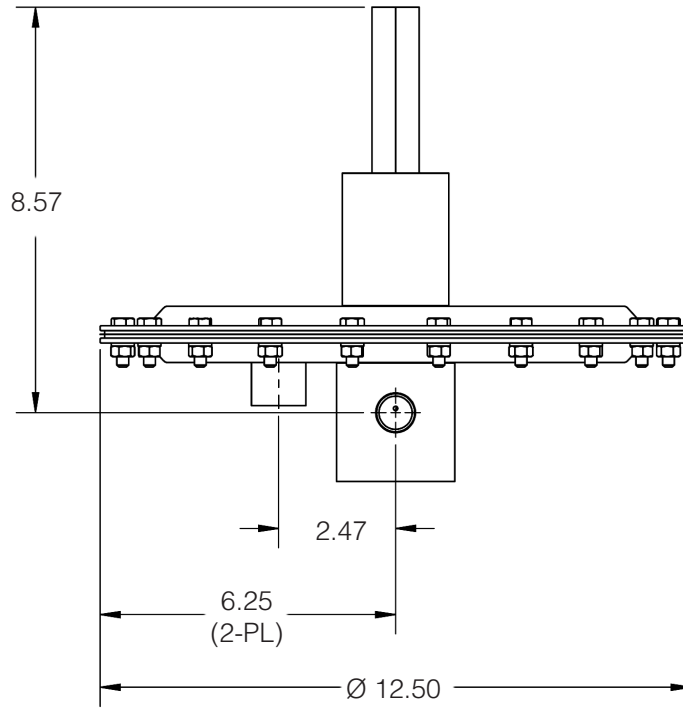

ORDERING SCHEMATIC FOR MK695X

Model No	Size	Body Mat'l	1	2	3	4	5	6	7	8	9	10	11	12

Model	
695X	Low Pressure

Press Switch	
AA	Not Req'd
ZZ	Non-Standard

Size	
050	1/2"
075	3/4"

Range	
A7	0.5-5" W.C.
A8	4-10 W.C.
ZZ	Non-Standard

Body Material	
SB	Stainless Steel (SA479)
ZZ	Non-Standard

Actuator	
S1	Standard
ZZ	Non-Standard

1 & 2	End Connections & Cv		
P	NPT	A	0.15
		B	0.20
		C	0.40
ZZ	Non-Standard		

Accessory	
G1	Inlet Gauge 0-100
G2	Inlet Gauge 0-200
P1	Purge System
ZZ	Non-Standard

Seat & O-Ring	
BN	Buna-N
VI	Viton
EP	EPDM
ZZ	Non-Standard

CAUTION: The following information is subject to change. Product Numbers and Description should be checked with the Factory for accuracy before Order Entry.

