

Mark 95AA Series

*"Send a signal
not a
technician"*

Sanitary Air Augmented Back Pressure Regulators

The Mark 95 with air augmentation (AA) option offers the same line sizes, Cv choices, seats, low build up characteristics, and stability of the standard bolted bonnet Mark 95, but with an advantage. By connecting an air pressure signal to the 1/4" FNPT dome fitting via an air regulator or I/P, the set point can be changed remotely by "sending an air signal instead of a technician".

The Mark 95AA and Mark 95AAFT gives users the ability to change pressure set points. Adjustments can be made with air pressure instead of, or in conjunction with, manual adjustment of the spring force to any point in excess of the springs minimum set point (2 psi on a 3/4" – 1" Mark 95, 3 psi on a 1-1/2", and 5 psi on a 2"). Users adjust the regulator's spring to the lowest set point (2 psi on a 3/4" for example), or to the lowest set pressure that the regulator will normally operate at (sterilization steam pressure for example), and use air pressure to charge the setpoint. To lower the set point to it's previous value, the pressure is reduced in the same manner.

The Mark 95AA and Mark 95AAFT are used in conjunction with a Steriflow self relieving I/P for control via PLC or DCS, or with a JSRLF regulator with self relieving option (For example - for remote control by valve mounted on wall, or panel outside of a cleanroom.)

FEATURES

- Reduce project CapEx. Remote regulator operation reduces the time required for system balancing, commissioning and validation of SIP and CIP routines.
- Complete range of products for any size or Cv requirement. The available sizes and Cv's are the same as the current MK95 product line.
- **Mark 95AA and Mark 95AAFT upgrade kits available for currently installed MK95 regulators.**
- With preset spring, users maintain control in the event of power (air failure). Valve will return to manual preset.

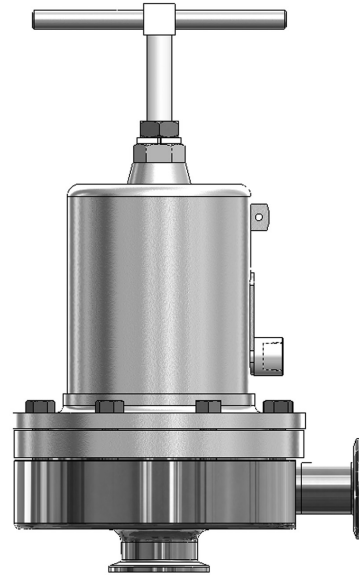

- Minimal build up when compared with all other spring loaded and air operated products, especially at higher set points.
- Extended permissible operating range when compared with all spring loaded and air load regulators.

DOCUMENTATION

The following documentation is shipped with each order:

- Steriflow Unicert
 - Certificate of Material Compliance with Traceable Material Heat Number for body and ferrules and MTRs
 - Certificate of Compliance to FDA and USP Class VI
 - Certificate of Surface Finish
- Final Test Reports and Certificate of Origin available upon request at time of order



Steriflow by Jordan Valve

3170 Wasson Road • Cincinnati, OH 45209
513.533.5600 • 800.543.7311 • 513.871.0105 (f)
steriflow@richardsind.com • www.steriflowvalve.com

Sizes: 1/2" (DN15), 3/4" (DN20), 1" (DN25), 1-1/2" (DN40), 2" (DN50), 3" (DN80)

End Connections

- Quick disconnect fittings (to match Tri-Clamp® fitting)
- DIN/ISO sanitary connections

Body & Trim Materials: 316L Stainless Steel (ASTM A47, S31603)

Seat Materials

- Optional soft seat (for Cv 1.5, 1" size and above)
 - Jorlon (FDA & USP Class VI) for steam and hot fluid service to 338°F (170°C)
 - PEEK (FDA & USP Class VI) for steam and hot fluid service to 350° (177°C)
 - PTFE to +252°F (122°C) continuous or 275°F (135°C) intermittent [not to exceed 15 min. in a one hour period] FDA, USP Class VI

Note: consult factory for 1/2" & 3/4" soft seat materials

Spring Housing Materials

- CF8M cast SST (1/2" – 1-1/2")
- Fabricated 316L SST (2" – 3")

Diaphragm Materials

- EPDM/Nylon (to 275°F, 135°C) – FDA only
- Jorlon (to 400°F, 204°C) – FDA, USP Class VI
- Ultra-thin Jorlon (to 400°F, 204°C), FDA, USP Class VI (for use with 3-8 range spring only)

O-Ring Materials

- EPDM (to 275°F, 135°C) - FDA, USP Class VI
- Buna-N (to 225°F, 107°C) - FDA
- Viton (to 400°F, 204°C) - FDA, USP Class VI
- Silicone (to 400°F, 204°C) - FDA, USP Class VI
- Teflon-Encapsulated Viton (to 400°F, 204°C) - FDA, USP Class VI
- Teflon-Encapsulated Silicone (to 400°F, 204°C) - FDA, USP Class VI (1-1/2" - 3")

Shutoff: Class VI soft seat; Class III hard seat

Body Pressure Temperature Rating: (dependent upon construction)

Valve Size	PSIG @ 100°F	PSIG @ 450°F
1/2", 3/4" & 1"	350 (24,1 bar)	250 (17,2 bar)
1-1/2", 2" & 3"	200 (13,8 bar)	200 (13,8 bar)

Pressure on 1/2", 3/4" & 1" size limited to 225 psig (15,5 bar) @ 100°F and 200 psig (13,8 bar) @ 400°F if using Ultra-thin Jorlon diaphragm.

Set Point Spring Ranges

Valve Size	Set Point Ranges, PSI (bar)
1/2", 3/4" & 1"	2-8* (0,1-0,6), 5-30 (0,3-2,1), 15-50 (1,0-3,4), or 35-90 (2,4-6,2)
1-1/2"	3-25* (0,2-1,7), 10-25 (0,7-1,7), 15-40 (1,0-2,8) or 35-85 (2,4-5,9)
2"	5-25* (0,3-1,7), 10-25 (0,7-1,7) or 15-60 (1,0-4,1)
3"	15-25 (1,0-1,7) or 15-60 (1,0-4,1)

* Range available with elastomer or Ultra-thin Jorlon diaphragm only. Maximum pressure drop 40 psi.

Cv (Kv) Ratings:

Valve Size	Elastomer & Jorlon Diaphragms Cvs (Kvs)
1/2", 3/4"***	0.5 (04,), 1.5 (1,3)
1"***	1.5 (1,3), 3.0 (2,6) or 5.5 (4,7)
1-1/2"	4.5 (3,9) or 10.0 (8,6)
2"	10.0 (8,6) or 19.0 (16,3)
3"	10.0 (8,6) or 28.0 (24,1)

** Cv's limited when using the 3-8 range spring- see rules in sizing program.

Maximum Allowable Pressure Differential: 200 psi (3-8 spring range has a max of 40 psi)

Maximum Allowable Pressure Setpoint: The total of the spring setpoint and additional air pressure cannot exceed:

- 1/2" – 1": 135 psi (9,3 bar)
- 1-1/2": 100 psi (6,9 bar)
- 2" – 3": 80 psi (5,5 bar)

Minimum Allowable Differential Pressure: No restrictions

Minimum Allowable Setpoint: Equivalent to the minimum spring rate set point:

- 1/2" – 1": 2 psi (0,14 bar)
- 1-1/2": 3 psi (0,21 bar)
- 2": 5 psi (0,34 bar)

Surface Finish: Refer to MK95 data sheet

FEATURES & BENEFITS

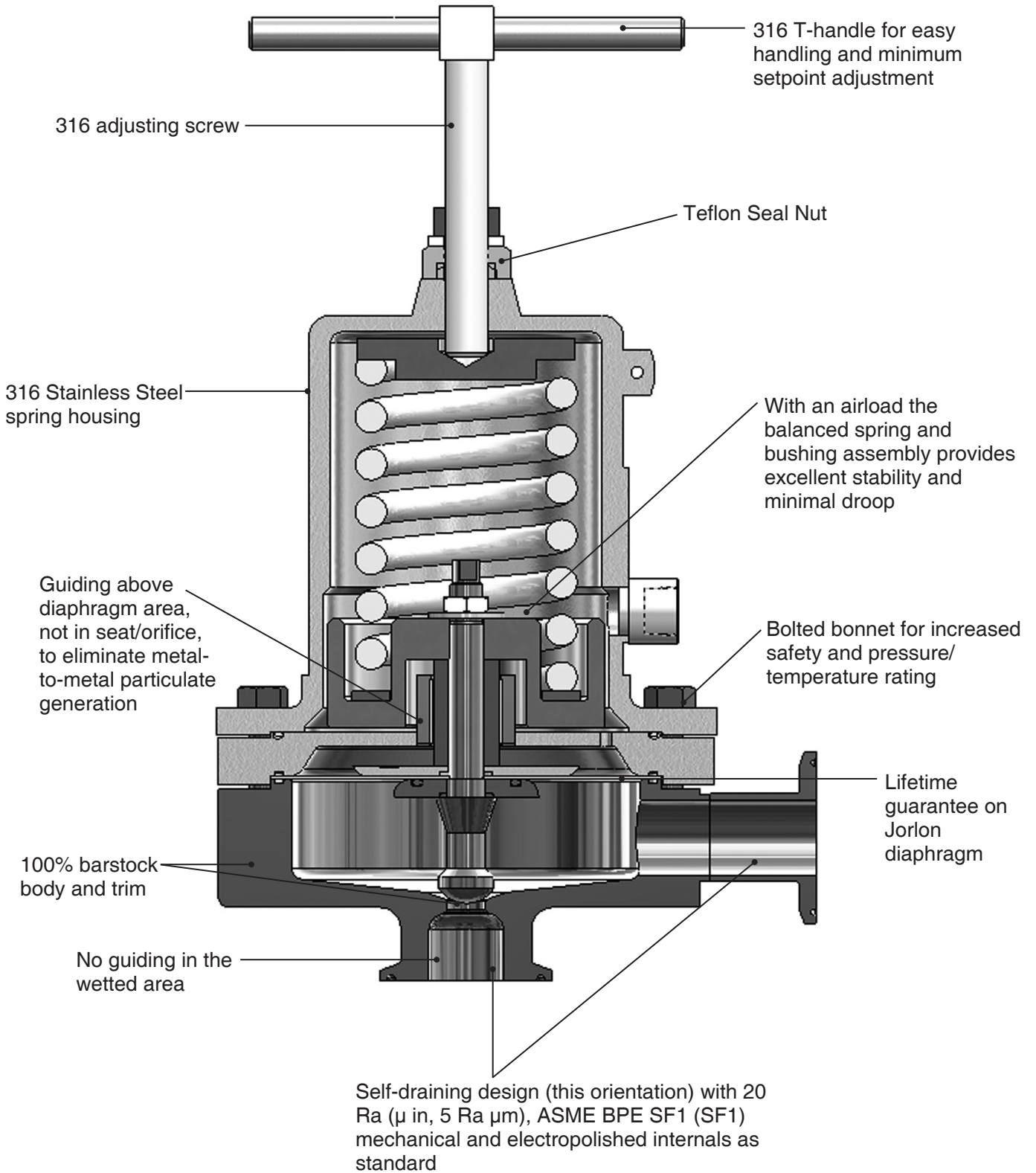

DIMENSIONS

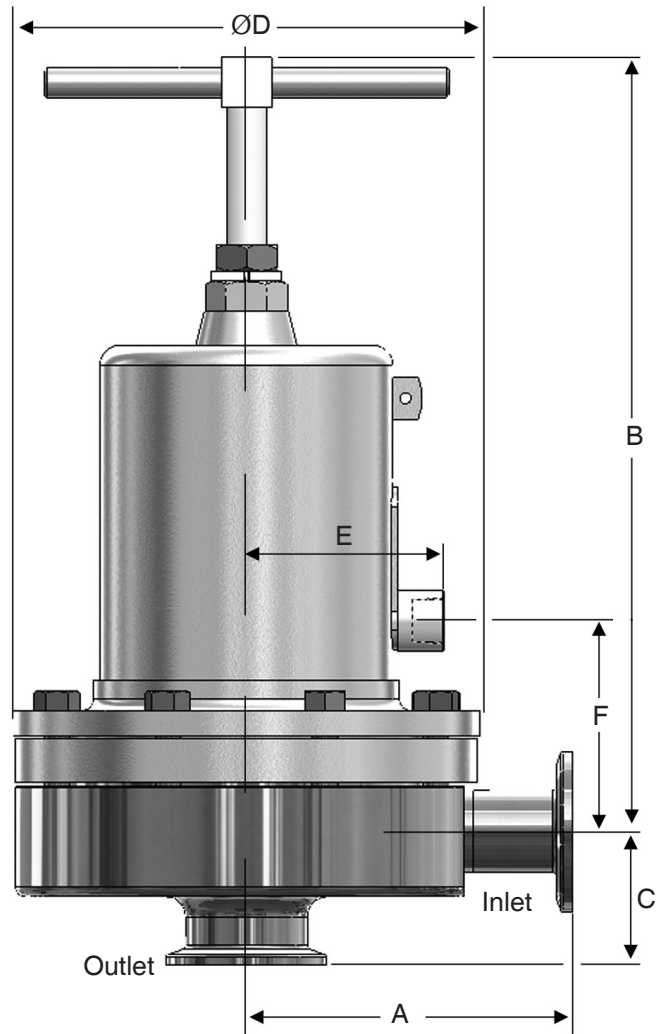

Valve Size	Dimensions (inches)						Weight Lbs
	A	B	C	D	E	F	
1/2"	3.29	8.00	1.37	5.70	2.44	2.44	18
3/4"	3.29	8.00	1.50	5.70	2.44	2.44	18
1"	4.00	8.00	1.64	5.70	2.44	2.57	20
1-1/2"	4.21	10.5	2.53	7.25	2.82	3.49	40
2"	5.34	17.5	2.96	9.50	3.83	4.89	90
3"	5.34	18.0	3.46	9.50	3.83	5.39	98

Valve Size	Dimensions (mm)						Weight Kgs
	A	B	C	D	E	F	
DN15	84	203	34,8	145	62	62	8,1
DN20	84	203	38,1	145	62	62	8,1
DN25	102	203	41,7	145	62	65	9,1
DN40	107	267	64,3	184	72	89	18
DN50	136	445	75,2	241	97	124	41
DN80	136	457	87,9	241	97	137	44

Based on US tri-clamp ends. Consult factory for DIN and ISO tri-clamp end dimensions

Refer to the MK95FT dimensional data sheet for the MK95FTAA dimensions.

SAMPLE SPECIFICATION

Stainless steel sanitary back pressure regulator shall be made from ASME-SA479 barstock material, which includes body and all wetted metal parts. Regulator shall utilize FDA approved, USP Class VI certified Jorlon diaphragm. Regulator shall be fully and remotely adjustable with the addition of a pneumatic air signal, to any set point above the minimum spring set point up to a maximum of 90 psi for sizes 1" and below; 85 psi for 1-1/2", and 60 psi for 2" & 3". In the event of air system failure, valve shall be manually adjustable. Guiding of valve stem/plug shall be completely outside of the wetted process areas of valve internals, above diaphragm per ASME BPE. Regulator shall be free of threads within wetted process areas and shall be self draining when installed with inlet vertical and below valve assembly.

SIZING AND SELECTION

In order to find out the actual Cv and/or flow rates for your application, complete the following:

1. Select the appropriate line size, required nominal Cv, and set point spring for your application from the charts on page 2, or from the ordering grid below.
2. Input that data, along with the installation inlet pressure, desired outlet pressure set point, and other required data into the Steriflow SFCV sizing program. If you do not have a copy of the sizing program, go to www.steriflowvalve.com and click on Technical/Valve Sizing Program or call your local Steriflow representative.
3. If the actual Cv, or flow rate (if solving for flow rate), are not sufficient for your application, then select and input a more appropriate valve Cv for that line size until you get an actual Cv that will work in your application. Note: if the actual Cv generated by the program is still not appropriate, you may be required to input a different valve line size, in order to obtain the correct Cv. Note, never select an automated valve by line size only.

Note: if ordering a Retrofit Kit for an existing Mark 95, you must provide the serial number of the Mark 95 with your RFQ or order.

ORDERING SCHEMATIC FOR MARK 95AA

					1 & 2	3 & 4	5 & 6	7 & 8	9 & 10	11 & 12	13 & 14
	—		—	/							

	Model
95AA	Standard
95FTAA	Flow-Through

	Size
050	1/2" (DN15)
075	3/4" (DN20)
100	1" (DN25)
150	1-1/2" (DN40)
200	2" (DN50)
300	3" (DN80)

	Body Material
6L	316L

1 & 2	Body	
	Finish	Cvs (Kvs)
A	20Ra Interior/63rms Exterior (Std)	A 0.5 & 1.5 (0,5 & 1,3)
B	20Ra Interior/20Ra Exterior	G 3.0 (2,6)
C	8Ra Interior/63rms Exterior*	H 4.5 (3,9)
D	20Ra Interior/8Ra Exterior	K 5.5 (4,7)
E	8Ra Interior/8Ra Exterior*	M 10.0 (8,6)
F	8Ra Interior/20Ra Exterior*	N 19.0 (16,3)
		P 28.0 (24,1)
ZZ	Non-Standard	

3	Trim Finish
A	20Ra (Standard)
B	8Ra

* Note: **Consult factory for parts to retrofit a MK95 into a MK95AA.** Retrofit kits may not be available for some MK95 project valves and valve models older than 2002. The valve serial number will identify your MK95's bill of material and is required for proper retrofit selection.

ORDERING SCHEMATIC FOR MARK 95AA

	—		—	/	1 & 2	3 & 4	5 & 6	7 & 8	9 & 10	11 & 12	13 & 14

4	Trim - CV & Seat
5	Cv 0.5 Hard Seat
A	Cv 1.5 Hard Seat
2	Cv 1.5 Jorlon Seat
E	Cv 3.0 Hard Seat
F	Cv 3.0 Teflon Seat
G	Cv 3.0 Jorlon Seat
H	Cv 4.5 Hard Seat
J	Cv 4.5 Teflon Seat
K	Cv 4.5 Jorlon Seat
L	Cv 5.5 Hard Seat
M	Cv 5.5 Teflon Seat
N	Cv 5.5 Jorlon Seat
P	Cv 10 Hard Seat
Q	Cv 10 Teflon Seat
R	Cv 10 Jorlon Seat
S	Cv 19 Hard Seat
T	Cv 19 Teflon Seat
U	Cv 19 Jorlon Seat
V	Cv 28 Hard Seat
W	CV 28 Teflon Seat
X	Cv 28 Jorlon Seat
Z	Non-standard

8	Range PSI (Bar)
A	2 - 8 (0,1 - 0,6)*
B	3 - 25 (0,3 - 1,7)*
D	5 - 30 (0,3 - 2,1)
E	10 - 25 (0,7 - 1,7)
F	5 - 25 (0,3 - 1,7)
P	15 - 25 (1,0 - 1,7)
G	15 - 40 (1,0 - 2,8)
H	15 - 50 (1,0 - 3,4)
J	15 - 60 (1,0 - 4,1)
K	35 - 85 (2,4 - 5,9)
L	35 - 90 (2,4 - 6,2)
Q	50 - 105 (3,4 - 7,2)
Z	Non-standard

* Must use EPDM or Ultra-thin Jorlon diaphragm

9 & 10	Diaphragm
EP	EPDM (all exterior)
JL	Jorlon (all exterior)
UJ	Ultra-thin Jorlon (all exterior)
ZZ	Non-standard

5 & 6	O-Ring/Diaphragm
EE	EPDM/EPDM Diaphragm
JE	EPDM/Jorlon Diaphragm
JK	Kalrez/Jorlon Diaphragm
JS	Silicone/Jorlon Diaphragm
JV	Viton/Jorlon
JY	Teflon/Silicone/Jorlon Diaphragm (1-1/2" - 3")
TY	Teflon Encaps. Viton/Jorlon Diaphragm
ZZ	Non-standard

11 & 12	Actuator Finish/Type
AA	Standard
BA	20Ra (SFV5) exterior
ZZ	Non-standard

13 & 14	PED Compliance
00	Not Required
0G	SEP/PED Compliant

7	Adjusting Screw Finish
A	Standard
B	20Ra (Except threads)
C	8Ra (Except threads)
Z	Non-standard

NOTE: If you want to use a small, manual air regulator to pressurize the 95AA, order a 1/4" JSRLF or JSRLF (with Teflon or EPDM seat) and self-relieving feature. Contact the factory for I/P selection.



Steriflow, a division of Jordan Valve

3170 Wasson Road • Cincinnati, OH 45209
 513.533.5600 • 800.543.7311 • 513.871.0105 (f)
 steriflow@richardsind.com • www.steriflowvalve.com

Steriflow Valve reserves the right to make revisions to its product, specifications, literature and related information without notice. Please visit our website at www.steriflowvalve.com for the latest information on our products.