

# Mark 56 Series

## Air Loaded Back Pressure Regulators

The Mark 56 is a highly accurate and economical air loaded back pressure regulator that provides regulation from a local station or from a remote station.

The operation of the MK56 requires no control spring or pilot. Instead, a static air signal is applied to the top of the diaphragm to determine the setpoint.

The MK56 has a rangeability of approximately 40:1; the same as our pilot-type sliding gate regulator, the MK57. However, unlike other piloted regulators, the MK56 has no minimum differential pressure requirement, and, because of its lack of a pilot valve, the MK56 is not as susceptible to problems caused by dirty service.

The MK56 offers an easily adjustable setpoint. The setpoint is based on changing the air load to the top of the main valve's diaphragm. Because of this, it is often found in applications in which the pressure it controls must be changed to differing setpoints during the manufacturing process. The maximum setpoint is equal to the maximum body pressure limit.



### FEATURES

- All metal to metal contacts — no gaskets or o-rings to wear out (2"/DN50 and under)
- Versatile application — use on steam, air, gas, liquids or chemicals
- Sliding Gate Seats — all of Jordan Valve's differential regulators feature advanced sliding gate seat technology.
  - Straight-through flow for reduced turbulence and quiet operation
  - Short stroke for fast response and accurate regulation.
  - Easily interchangeable Cv's
  - Tight Shutoff

### SPECIFICATIONS

**Sizes:** 1/2" through 6" (DN15 through DN150)

#### End Connections:

- Threaded — FNPT, BSPT, BSPP
- ANSI Flanges — 150#, 300#
- DIN Flanges — PN10/16, PN25/40
- JIS Flanges — 10K, 20K

#### Body Materials:

- Ductile Iron
- Bronze (1/2" to 2" only/DN15 to DN50)
- Carbon Steel
- Stainless Steel
- Cast Iron (2-1/2" to 6" only/DN65 to DN150)

#### Trim Materials:

- 303SS for DI, CI, BRZ & CS body valves
- 316 for SS body valves
- Jorcote on SST — Standard
- Jorcote/Jordanic on SST — For severe service
- Chrome Plated SST — Optional



**Jordan Valve, a division of Richards Industries**  
3170 Wasson Road • Cincinnati, OH 45209  
513.533.5600 • 800.543.7311 • 513.871.0105 (f)  
info@richardsind.com • www.jordanvalve.com

**SPECIFICATIONS (CONT'D)**

**Diaphragm Materials:**

- Stainless Steel
- Jorlon
- Viton
- Buna-N

**Diaphragm Case:**

- DI (1/2" to 2"/DN15 to DN50)
- Steel (2-1/2" to 6"/DN65 to DN150)

**Dome Loading Pressure:** matches body pressure rating

**Service:** steam, water, air, gas, oil, chemicals

**Shutoff:** ANSI Class IV

**Cv (Kv) Values & Maximum Differential Pressures:**

Cv* (Kv)	Valve Size (DN)	Seat Material	Max ΔP, PSI (Bar)
2.5 (2,15)	1/2" & 3/4" (DN15 & DN20)	SST	125 (92)
		Jorcote	400 (28)
4.4 (3,78)	1/2" & 3/4" (DN15 & DN20)	SST	125 (9)
		Jorcote	400 (28)
6.4 (5,50)	1 & 1-1/4" (DN25 & DN32)	SST	125 (9)
		Jorcote	400 (28)
9.5 (8,2)	1 & 1-1/4" (DN25 & DN32)	SST	125 (9)
		Jorcote	400 (28)
15 (12,9)	1-1/2" (DN40)	SST	75 (5)
		Jorcote	325 (22)
25 (21,5)	2" (DN50)	SST	75 (57)
		Jorcote	325 (221)
30 (25,8)	2" (DN50)	SST	75 (57)
		Jorcote	325 (22)
55 (47,3)	2-1/2" (DN65)	Jorcote	150 (10)
115 (98,9)	3" (DN80)	Jorcote	150 (10)
200 (172)	4" (DN100)	Jorcote	150 (10)
395 (339,7)	6" (DN165)	Jorcote	150 (10)

**MK56 Cut-A-Way View**

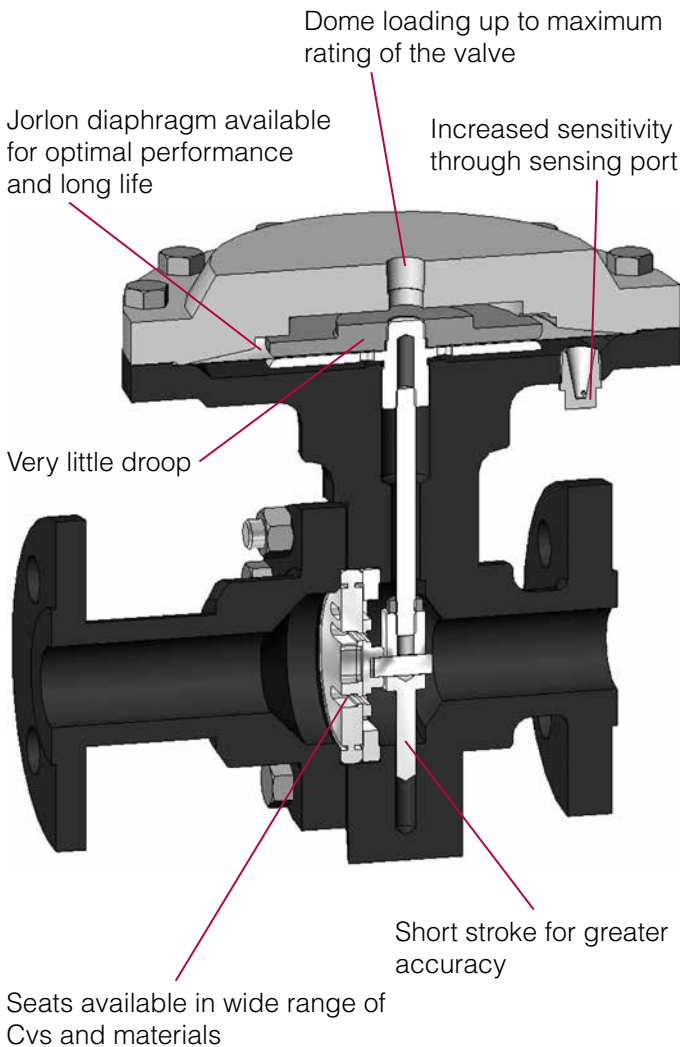

**\*Low Flow Cv's (Kv's) available:** reduced Cv's (Kv's) can be placed in any size valve as long as it is a smaller value than the standard Cv (Kv) for that particular size. In addition, the following special low flows can be provided:

1.6 (1,38)	0.84 (0,72)	0.42 (0,36)	0.21 (0,18)	0.08 (0,07)	0.04 (0,03)
0.02 (0,017)	0.008 (0,007)	0.004 (0,003)	0.002 (0,002)	0.0008 (N/A in 316SS) (0,00069)	

**Body Rating:**

- Ductile Iron up to 600 psi (41,37 bar) @ 100°F (38°C) and 600 psi (41,37 bar) @ 650°F (343,3°C). *Note: Double bolting is required to reach these pressures. Consult factory for details.*
- Carbon Steel and Stainless Steel up to 950 psi (65,50 bar) @ 100°F (38°C) and 890 psi (61,36 bar) @ 650°F (343,3°C). *Note: Double bolting is required to reach these pressures. Consult factory for details.*
- Bronze up to 500 psi (34,5 bar) @ 100°F (38°C) and 325 psi (22,41 bar) @ 500°F (260°C)
- Temperature limit of -20°F (-28,9°C) on all materials; for other temperatures, consult factory

# MARK 56 AIR LOADED BACK PRESSURE REGULATOR

## DIMENSIONS

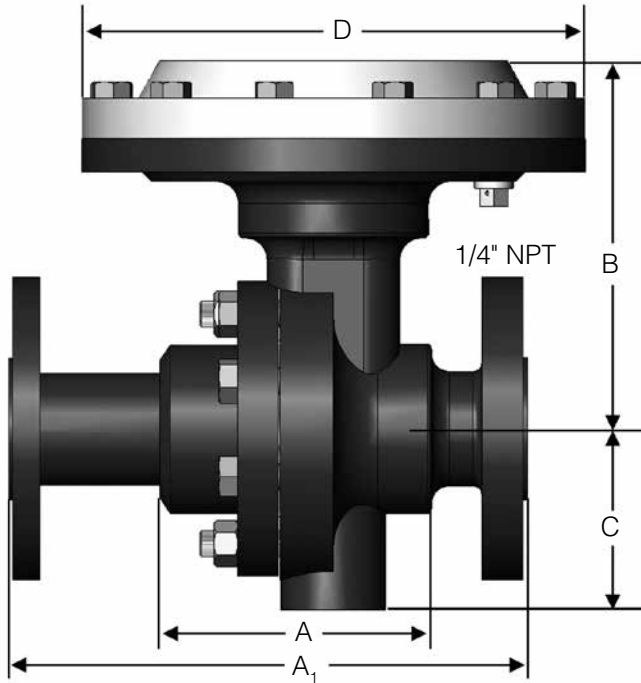

- Flanged Ends

Size	Flange	Dimensions (inches)						Weight (lbs.)	
		A1		B		C	D	DI/BRZ	CS/SS
		DI/BRZ	CS/SS	DI/BRZ	CS/SS	All	All		
1/2"	150#	9.62	9.62	4.11	4.03	1.69	7.12	18	21
	300#	9.62	10.25	4.11	4.03	1.69	7.12	20	23
3/4"	150#	9.62	9.62	4.11	4.03	1.69	7.12	20	23
	300#	9.62	10.25	4.11	4.03	1.69	7.12	22	25
1"	150#	7.25	7.25	4.31	4.60	2.62	7.12	22	27
	300#	8.75	7.75	4.31	4.60	2.62	7.12	24	29
1 1/4"	150#	7.87	—	4.31	—	2.22	7.12	22	—
	300#	8.37	—	4.31	—	2.22	7.12	26	—
1 1/2"	150#	8.75	8.75	4.27	4.85	2.31	7.12	26	30
	300#	10.25	9.25	4.27	4.85	2.31	7.12	32	36
2"	150#	10.00	10.00	4.49	4.82	2.75	7.12	32	36
	300#	10.50	10.50	4.49	4.82	2.75	7.12	36	40
Larger Sizes (only for DI/CS/SS)									
Size	ANSI Flange	Dimensions (inches)				Weight (lbs.)			
2 1/2"	125-150#	10.87	10.68	6.93	12.75	160			
	250-300#	11.50	10.68	6.93	12.75	160			
3"	125-150#	11.75	10.68	6.93	12.75	180			
	250-300#	12.50	10.68	6.93	12.75	180			
4"	125-150#	13.87	11.88	8.00	12.75	210			
	250-300#	14.50	11.88	8.00	12.75	210			
6"	125-150#	17.75	12.57	9.00	12.75	300			
	250-300#	18.62	12.57	9.00	12.75	300			

- Flanged Ends, DIN

Size (DN)	Flange (PN)	Dimensions (mm)						Weight (kg)	
		A1		B		C	D	DI/BRZ	CS/SS
		DI/BRZ	CS/SS	DI/BRZ	CS/SS	All	All		
15	10/16	244	244	104	102	43	181	8,2	9,5
	25/40	244	260	104	102	43	181	9,1	10,4
20	10/16	244	244	104	102	43	181	9,1	10,4
	25/40	244	260	104	102	43	181	10,0	11,3
25	10/16	184	160	109	117	67	181	10,0	12,2
	25/40	184	160	109	117	67	181	10,9	13,2
32	10/16	200	—	109	—	67	181	10,0	—
	25/40	200	—	109	—	67	181	11,8	—
40	10/16	222	200	108	123	59	181	11,8	13,6
	25/40	222	200	108	123	59	181	14,5	16,3
50	10/16	254	230	114	122	70	181	14,5	16,3
	25/40	254	230	114	122	70	181	16,3	18,1
Larger Sizes (only for DI/CS/SS)									
Size (DN)	Flange (PN)	Dimensions (mm)				Weight (kg)			
65	10/16	283	271	176	324	73			
	25/40	283	271	176	324	73			
80	10/16	312	271	176	324	82			
	25/40	312	271	176	324	82			
100	10/16	350	302	203	324	95			
	25/40	350	302	203	324	95			
150	10/16	471	320	229	324	136			
	25/40	471	320	229	324	300			

- Threaded Ends

Size	Mat'l	Dimensions (inches)				Weight (lbs.)
		A	B	C	D	
1/2 & 3/4"	DI/BRZ	3.62	4.11	1.69	7.12	16
	CS/SS	3.62	4.03	1.69	7.12	19
1"	DI/BRZ	4.12	4.31	2.62	7.12	18
	CS/SS	4.18	4.60	2.62	7.12	23
1-1/4"	DI/BRZ	4.12	4.31	2.62	7.12	18
1-1/2"	DI/BRZ	4.50	4.27	2.31	7.12	20
	CS/SS	4.81	4.85	2.25	7.12	24
2"	DI/BRZ	4.50	4.49	2.75	7.12	22
	CS/SS	5.50	4.82	2.75	7.12	26

- Threaded Ends, DIN

Size (DN)	Mat'l	Dimensions (mm)				Weight (kg)
		A	B	C	D	
15 & 20	DI/BRZ	92	104	43	181	7,3
	CS/SS	92	104	43	181	8,6
25	DI/BRZ	105	109	67	181	8,2
	CS/SS	106	117	67	181	10,4
32	DI/BRZ	105	109	67	181	8,2
40	DI/BRZ	114	108	59	181	9,1
	CS/SS	122	123	59	181	10,9
50	DI/BRZ	114	114	70	181	10,0
	CS/SS	140	122	70	181	11,8

**ORDERING SCHEMATIC**

To specify a MK56 Air Loaded Back Pressure Regulator, build a model number by making a selection from each category in the Product Designator Coding System below.

<b>1</b>		<b>2</b>		<b>3</b>	/	<b>4</b>	<b>5</b>	<b>6</b>	<b>7</b>	<b>8</b>	<b>9</b>	<b>10</b>	<b>11</b>	<b>12</b>

<b>1</b>	<b>Model</b>	
	56	Standard

<b>2</b>	<b>Size</b>	
	050	1/2" (DN15)
	075	3/4" (DN20)
	100	1" (DN25)
	125	1-1/4" (DN32)
	150	1-1/2" (DN40)
	200	2" (DN50)
	250	2-1/2" (DN65)
	300	3" (DN80)
	400	4" (DN100)
	600	6" (DN150)

<b>3</b>	<b>Body Material</b>	
	DI	Ductile Iron
	BR	Bronze
	CS	Carbon Steel (WCB)
	S6	Stainless Steel (CF8M)
	CI	Cast Iron

<b>4</b>	<b>End Connections</b>	
	PT	NPT
	BT	BSPT
	BP	BSPP
	SW	FSW
	I1	125# IFE
	F1	125# FE (except IFE)
	I5	150# IFE
	F5	150# FE (except IFE)
	I2	250# IFE
	F2	250# FE (except IFE)
	I3	300# IFE
	F3	300# FE (except IFE)
	ZZ	Non-Standard

<b>5</b>	<b>Trim</b>	
	S3	303SS
	S6	316SS
	I3	303SS F/IFE
	I6	316SS F/IFE
	ZZ	Non-Standard

<b>6</b>	<b>Seat Material</b>	
	A	303SST
	B	316SST
	V	303SS/Jorcote
	W	316SS/Jorcote
	X	303SS/Jorcote/Jordanic
	Y	316SS/Jorcote/Jordanic

<b>7</b>		<b>Cv</b>	<b>Kv</b>		<b>Cv</b>	<b>Kv</b>
	1	0.21	0,18	A	25	21,5
	2	0.42	0,36	B	30	25,8
	3	0.84	0,72	D	55	47,4
	4	1.6	1,4	F	85	73,3
	5	2.5	2,2	G	115	99,1
	6	4.4	3,8	H	130	112,1
	7	6.4	5,5	I	200	172,4
	8	9.5	8,2	J	395	340,5
	9	15	12,9			

<b>8</b>	<b>Range</b>	
	00	None

<b>9</b>	<b>Diaphragm</b>	
	S6	316SST
	VI	Viton
	BN	Buna-N
	JL	Jorlon
	DD	Separate Double Diaphragm
	ZZ	Non-Standard

<b>10</b>	<b>Actuator</b>	
	MD	For Metal Diaphragm
	ED	For Elastomer Diaphragm
	ZZ	Non-Standard

<b>11</b>	<b>Double Bolting</b>	
	00	None
	DZ	Double Bolting

<b>12</b>	<b>Accessories</b>	
	0	None
	6	316SS Bolting
	7	Hi Temperature Bolting
	Z	Non-Standard

