

Mark 96 Series

Sanitary Pressure Regulators



CRN Registration Number Available

The Mark 96 Sanitary Pressure Regulator is designed to regulate pressure in systems requiring the maintenance of sanitary conditions.

The Mark 96 operates by sensing pressure under the diaphragm on the downstream side of the seat. As the downstream pressure approaches the set point, the force caused by the pressure acting on the diaphragm overcomes the force of the range spring, and the plug begins to move up toward closed. This reduces the downstream pressure and maintains the set point. If the pressure underneath the diaphragm begins to fall, the spring forces the plug to move down towards open, to allow the set point to be maintained.

FEATURES

- **New!** DIN & ISO Tri-Clamp and tube weld ends - available as options
- **New!** Optional Gauge Port
- CRN Registration Number Available
- Soft seat capability for ANSI Class VI shutoff
- No guiding surfaces in the fluid below the diaphragm in the wetted area. ASME BPE compliant
- 100% 316L barstock body – no wetted parts made from castings
- Self-draining
- Best Accuracy (least droop -set point offset) in the industry. Ask your rep for a MK96 performance calculator demonstration
- Clean-in-Place, Steam-in-Place – dome lock pin to allow CIP/SIP
- Jorlon diaphragm: PTFE based material provides excellent chemical resistance and extremely long life in steam service. Far superior to other elastomer or metal diaphragm materials. *Ask your local Representative for cycle testing information.*

DOCUMENTATION

The following documentation is shipped at no charge:

- Steriflow Unicert: Certificate of Compliance for:
 - Material, including MTR's
 - Surface Finish
 - FDA/USP Class VI
- Traceability:
 - Each Unicert includes individual valve serial numbers, heat numbers and attached MTR's directly traceable to the valve serial number, and heat numbers on all wetted metallic components



3/4" – 1"



1 1/2" – 3"

APPLICATIONS

A wide variety of applications exist for the MK96 in the pharmaceutical, biotech, health-care, food & beverage and other industries.

AVAILABLE FINISHES

Body:

- *Standard:* 20 Ra µin (0,5 Ra µm) (ASME BPE SF5) mechanical finish and electropolish on inside wetted surfaces; 40 Ra µin (1 Ra µm) and electropolish on exterior.
- *Optional:* 20 Ra µin (0,5 Ra µm) SF5 mechanical finish and electropolish on external surfaces; 8 Ra µin (0,2 Ra µm) finish on internal or external finishes and electropolish (Better than SF4)

Spring Housing:

- *Standard:* machined or investment cast finished 316SST, electropolished
- *Optional:* 20 Ra µin (0,5 Ra µm) mechanical finish and electropolish on external surfaces (SF5). 8 Ra µin (0,2 Ra µm) finish on external surfaces on all sizes and electropolish. (Better than SF4)

Adjusting Screw and Handle:

- *Standard:* 32Ra µin electropolished (Note: adjusting screw is a threaded part)
- *Optional:* 20 Ra µin (0,5 Ra µm) mechanical finish and electropolish finish (SF5)

SPECIFICATIONS

Sizes: 3/4", 1", 1-1/2" 2", 3"; DIN DN20, DN25, DN40, DN50, DN80; ISO DN20, DN25, DN40, DN50, DN80

End Connections:

- ASME Tri-Clamp
- ASME Tube Weld Ends
- DIN/ISO Tri-Clamp Conn's to DIN 32676 Row A, B
- DIN/ISO Tube Weld Ends to DIN 11866 Row A, B

Gauge Port: 3/4" ASME BPE Hygienic Tri-clamp

Body Connections: Mark 96 – Bolted – Standard for all sizes

Body & Trim Materials:

- ASTM A479 316L (other materials upon request)

Seat Materials:

- Standard hard seat – integral 316L SST seat
- Optional soft seat
 - Jorlon (for Cv 1.5, 3/4" size and above) (FDA & USP Class VI) for steam and hot fluid service to 338°F (170°C)
 - Teflon (for Cv 1.5, 1" (DN25) size and above) to 252°F (122°C) continuous or 275°F (135°C) intermittent [not to exceed 15 min. in a one hour period] FDA, USP Class VI
 - PEEK (3/4" and above) (FDA & USP Class VI) for steam and hot fluid service to 350° (177°C)

Note: consult factory for how to order PEEK soft seat materials

SPECIFICATIONS (CON'T)

Spring Housing Materials:

- 3/4" - 1" (DN15-DN25):
 - Material: A351 CF8M 316SS Investment casting, if SF5 or better finish required, fabricated 316L
- 1 1/2" - 3" (DN 40 - DN80):
 - Material: Fabricated 316L

Diaphragm Materials:

- Jorlon (to 400°F, 204°C) – FDA, USP Class VI
- 316L SST
- EPDM/Nylon (to 275°F, 135°C), FDA only
- Ultra-thin Jorlon (to 400°F, 204°C), FDA, USP Class VI (for use with 3-8 range spring only)

O-Ring Materials:

- EPDM (to 275°F, 135°C) – FDA, USP Class VI
- Buna-N (to 225°F, 107°C) – FDA
- Viton (to 400°F, 204°C) – FDA, USP Class VI
- Silicone (to 400°F, 204°C) – FDA, USP Class VI
- Teflon-Encapsulated Viton (to 400°F, 204°C) – FDA, USP Class VI
- Teflon-Encapsulated Silicone (to 400°F, 204°C) – FDA, USP Class VI (1" - 3" only)

Shutoff: ANSI Class III hard seat or Class VI soft seat

Body Pressure Temperature Rating: (dependent upon construction)

Valve Size	PSIG @ 100°F	PSIG @ 450°F
3/4", 1", DN20, DN25	350 (24,1 bar)	250 (17,2 bar)
1-1/2", 2", 3", DN40, 50, 80	200 (13,8 bar)	200 (13,8 bar)

Pressure on 1/2", 3/4" & 1" size limited to 225 psig (15,5 bar) @ 100°F and 200 psig (13,8 bar) @ 400°F if using Ultra-thin Jorlon diaphragm.

Note: for 1/2" size, refer to our Mark 96C datasheet

Set Point Spring Ranges:

Valve Size	Set Point Ranges, PSI (bar)
3/4" & 1" DN20 & DN25	3-8* (0,2-0,5), 5-25 (0,37-1,7), 15-50 (1,0-3,4), 40-90 (2,7-6,2), or 75-135 (5,2-9,3)
1-1/2", DN40	10-25 (0,7-1,7), 15-50 (1,0-3,4) or 35-100 (2,4-6,9)
2", DN50	10-25 (0,7-1,7) or 15-60 (1,0-4,1)
3", DN80	15-25 (1,0-1,7) or 15-60 (1,0-4,1)

* Range available with elastomer or Ultra-thin Jorlon diaphragm only. Maximum pressure drop 40 psi.

SPECIFICATIONS (CON'T)

Cv (Kv) Ratings:

Valve Size	Available Cv (Kv)	Cv for Relief Valve Sizing
3/4"*** DN20	1.5 (1,3)	3.8 (3,27)
1"*** DN25	1.5, 2.5, 4.5, 5.5**, 6.1** (1,3; 2,2; 3,9; 4,7; 5,3)	10.7 (9,2)
1-1/2" DN40	4.5 or 10.0 (3,9 or 8,6)	6.7 (5,76); 26.3 (22,6)
2" DN50	10.0 or 19.0 (8,6 or 16,3)	16.5 (14,2), 56.5 (48,6)
3" DN80	10.0 or 23.0 (8,6 or 19,8)	16.5 (14,2); 67.1 (57,7)

Set Point	Sizing Limit (of rated capacity)
8	50%
5	33%
3	25%

For example, a 1" (DN25) Cv5.5 valve with a 3-8 range spring, if the customer's set point is P2 = 8 psi, then the actual Cv sizing should not exceed 2.75Cv. If the customer's intended set point is P2 = 5 psi, then the actual Cv sizing should not exceed 1.8Cv and if their set point is P2 = 3 psi, then the actual Cv sizing should not exceed 1.38 Cv.

Maximum Allowable Pressure Differential: 200 psi (3-8 spring range has a max of 40 psi)

Note: Steriflow does not recommend using metal seated trim on any service where the flow will be deadheaded downstream of the pressure reducing regulator. Use an appropriate Teflon, Jorlon or Peek soft seat for the trim instead.

- ** Not available with metal diaphragms, Jorlon and other elastomers acceptable
- *** When using the 3-8 range spring the following sizing limits apply:

FEATURES & BENEFITS

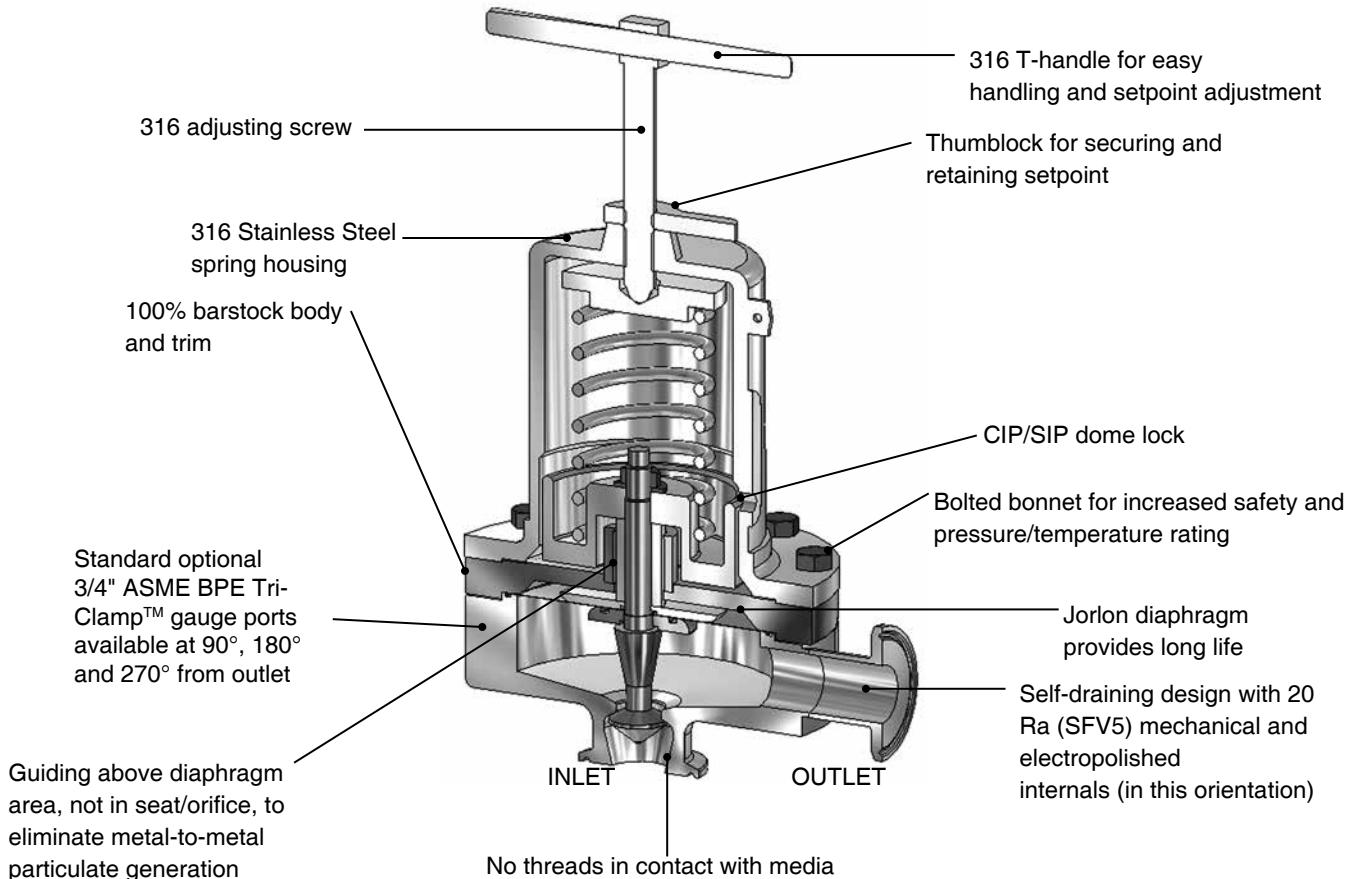

CAPACITY Cv AT VARIOUS DROOP %

Mark 96	Set Pressure PSIG (BAR)	7					Cv for Relief Valve Sizing
		5%	10%	15%	20%	30%	
3/4", DN15 or DN20 1.5 Cv (1,3 Kv) 15 to 50 psi (1,0 - 3,4 bar) range	15 (1,0)	0.10	0.20	0.31	0.42	0.65	3.8 (3,3 Kv)
	20 (1,4)	0.12	0.26	0.39	0.54	0.83	
	25 (1,7)	0.15	0.31	0.47	0.64	1.01	
	30 (2,1)	0.18	0.36	0.55	0.75	1.17	
	35 (2,4)	0.20	0.41	0.63	0.85	1.34	
	40 (2,8)	0.22	0.46	0.70	0.96	1.50	
	45 (3,1)	0.25	0.51	0.77	1.06	1.50	
1", DN25 4.5 Cv (3,9 Kv) 15 to 50 psi (1,0 - 3,4 bar) range	15 (1,0)	0.30	0.61	0.93	1.26	1.95	10.7 (9,3 Kv)
	20 (1,4)	0.37	0.77	1.18	1.61	2.50	
	25 (1,7)	0.46	0.93	1.42	1.93	3.02	
	30 (2,1)	0.53	1.08	1.65	2.25	3.52	
	35 (2,4)	0.60	1.23	1.88	2.56	4.02	
	40 (2,8)	0.67	1.37	2.10	2.87	4.50	
	45 (3,1)	0.74	1.52	2.32	3.18	4.50	
1-1/2", DN40 10 Cv (8,6 Kv) 15 to 50 psi (1,0 - 3,4 bar) range	15 (1,0)	0.59	1.20	1.85	2.54	4.05	26.3 (22,8 Kv)
	20 (1,4)	0.66	1.36	2.10	2.91	4.68	
	25 (1,7)	0.72	1.48	2.30	3.19	5.16	
	30 (2,1)	0.77	1.57	2.45	3.40	5.55	
	35 (2,4)	0.80	1.65	2.57	3.58	5.86	
	40 (2,8)	0.83	1.71	2.67	3.73	6.13	
	45 (3,1)	0.86	1.76	2.75	3.85	6.35	
2", DN50 19 Cv (16,3 Kv) 15 to 60 psi (1,0 - 4,1 bar) range	15 (1,0)	1.89	3.85	5.84	7.87	12.02	56.5 (49,0 Kv)
	20 (1,4)	2.66	5.40	8.19	11.04	16.88	
	25 (1,7)	3.48	7.08	10.73	14.46	19.00	
	30 (2,1)	4.41	8.91	13.47	18.17	19.00	
	35 (2,4)	5.37	10.92	16.52	19.00		
	40 (2,8)	6.45	13.16	19.00			
	45 (3,1)	7.77	15.68	19.00			
3", DN80 23 Cv (19,8 Kv) 15 to 60 psi (1,0 - 4,1 bar) range	15 (1,0)	4.09	6.83	9.40	11.81	16.20	67.1 (58,2 Kv)
	20 (1,4)	5.03	8.56	11.81	14.79	20.10	
	25 (1,7)	6.31	10.99	15.23	19.11	23.00	
	30 (2,1)	7.29	12.73	17.60	21.98	23.00	
	35 (2,4)	8.24	14.42	19.85	23.00		
	40 (2,8)	9.17	16.04	21.98	23.00		
	45 (3,1)	10.09	17.60	23.00			
	50 (3,4)	10.99	19.11	23.00			
	55 (3,8)	11.87	20.57	23.00			
60 (4,1)	12.73	21.98	23.00				

Note: for capacity Cv (Kv) and performance at other conditions, please visit the Technical Library on our website at www.steriflowvalve.com

DIMENSIONS

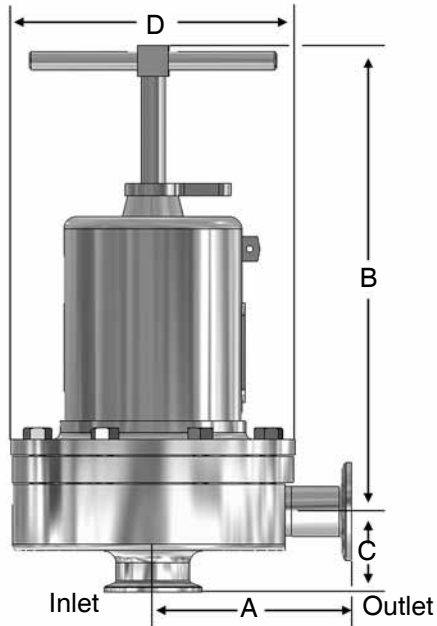

- ASME Tri-Clamp Ends

Valve Size	Dimensions (inches)				Weight Lbs
	A	B	C	D	
3/4"	3.29	8.00	1.50	5.70	18
1"	4.00	8.00	1.64	5.70	20
1-1/2"	4.21	10.50	2.53	7.25	40/28.7*
2"	5.34	17.50	2.96	9.50	90/66**
3"	5.34	18.00	3.46	9.50	98

- ASME Tri-Clamp Ends, mm

Valve Size	Dimensions (mm)				Weight Kgs
	A	B	C	D	
3/4"	83,6	203	38,1	144,8	8
1"	101,6	203	41,7	144,8	9
1-1/2"	106,9	267	64,3	184,2	18/13*
2"	135,6	445	75,2	241	41/30**
3"	135,6	457	87,9	241	44

- ASME Tube Weld Ends, inches

Valve Size	Dimensions (inches)				Weight Lbs
	A	B	C	D	
3/4"	3.32	8.00	1.88	5.70	18
1"	3.34	8.00	2.18	5.70	20
1-1/2"	4.68	10.50	3.67	7.25	40/28.7*
2"	5.34	17.50	2.96	9.50	90/66**
3"	5.34	18.00	3.46	9.50	98

- ASME Tube Weld Ends, mm

Valve Size	Dimensions (mm)				Weight Kgs
	A	B	C	D	
3/4"	84,3	203	47,8	144,8	8,2
1"	84,8	203	55,4	144,8	9,1
1-1/2"	118,9	267	93,2	184,2	18/13*
2"	135,6	444	75,2	241	41/30**
3"	135,6	457	87,9	241	44

- DIN Tri-Clamp Connections to DIN 32676 Row A

Valve Size	Dimensions (mm)				Weight Kgs
	A	B	C	D	
15	100,3	203,2	63,6	146,1	8,1
20	99,7	203,2	70,2	146,1	8,1
25	99,7	203,2	72,8	146,1	9,1
40	118,3	266,7	83,6	183,4	18/13*
50	145,8	444,5	93,9	240,5	41/30**
80	146,6	457,2	105	240,5	44,4

- DIN Tube Weld Ends to DIN 11866 Row A

Valve Size	Dimensions (mm)				Weight Kgs
	A	B	C	D	
15	93,4	203,2	56,7	146,1	8,1
20	92,8	203,2	63,3	146,1	8,1
25	92,8	203,2	65,9	146,1	9,1
40	111,4	266,7	76,7	183,4	18/13*
50	138,9	444,5	87	240,5	41/30**
80	139,7	457,2	98,1	240,5	44,4

- ISO Tri-Clamp Connections to DIN 32676 Row A

Valve Size	Dimensions (mm)				Weight Kgs
	A	B	C	D	
15	92,1	203,2	62,5	146,1	8,1
20	92,1	203,2	62,5	146,1	8,1
25	92,1	203,2	65,3	146,1	9,1
40	110,6	266,7	76,8	183,4	18/13*
50	138,2	444,5	93,9	240,5	41/30**
80	138,9	457,2	96,8	240,5	44,4

- ISO Tube Weld Ends to DIN 11866 Row B

Valve Size	Dimensions (mm)				Weight Kgs
	A	B	C	D	
15	92,1	203,2	62,5	146,1	8,1
20	92,1	203,2	62,5	146,1	8,1
25	92,2	203,2	65,3	146,1	9,1
40	110,6	266,7	76,8	183,4	18/13*
50	138,2	444,5	93,9	240,5	41/30**
80	138,9	457,2	96,8	240,5	44,4

* 40 lbs (18,1 kgs) std; 28.7 lbs (13 kgs) with aluminum spring housing

** 90 lbs (40,7 kgs) std; 66 lbs (33 kgs) with aluminum spring housing

GAUGE PORT CONFIGURATION OPTIONS

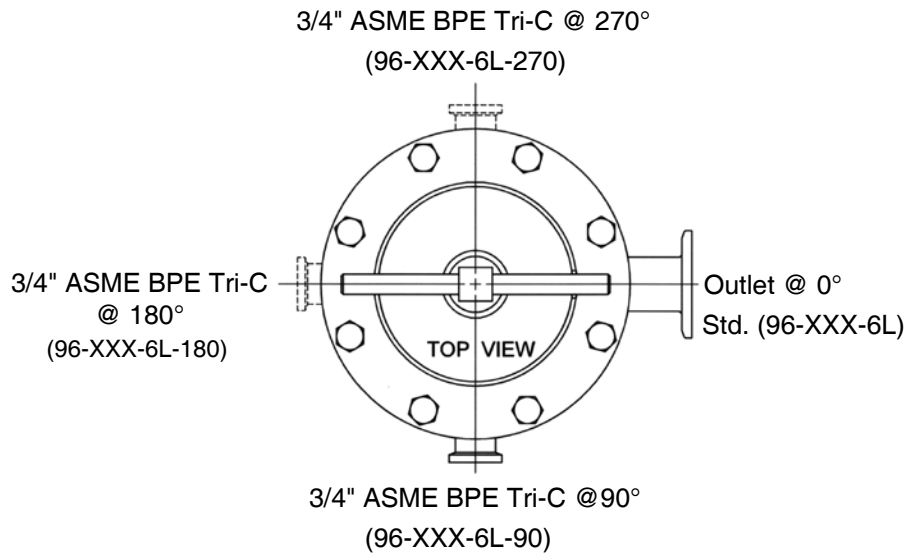

SAMPLE SPECIFICATION

Stainless steel sanitary pressure regulator shall be made from ASME-SA479 316L barstock material, which includes body and all wetted metal parts. Regulator shall be activated by FDA approved, USP Class VI certified Jorlon diaphragm. Guiding of valve stem/plug shall be outside of the wetted, process areas of valve internal, above the diaphragm only. Regulator shall be free of threads or crevices within wetted, process areas of valve internal and shall be self draining when installed with inlet vertical and below valve assembly.

ORDERING SCHEMATIC

							1 & 2	3 & 4	5 & 6	7 & 8	9 & 10	11 & 12	13 & 14

Model	
96	ASME BPE Tri-Clamp Connections
96T	ASME BPE Tube Weld Ends
96D	DIN Tri-Clamp Conn's to DIN 32676 Row A
96DT	DIN Tube Weld Ends to DIN 11866 Row A
96S	ISO Tri-clamp Conn's to DIN 32676 Row B
96ST	ISO Tube Weld Ends to DIN 11866 Row B

Size	
075	3/4"
100	1"
150	1-1/2"
200	2"
300	3"
15	DN15
15N*	DN15 Non-standard Face
20	DN20
20N*	DN20 Non-standard Face
25	DN25
40	DN40
50	DN50
80	DN80

* DIN or ISO tri-clamp face not conforming to DIN standard 32676. State face size as noted on P.O.

Material	
6L	316L

Body Configuration- Standard or Gauge Port*	
	Standard - no gauge port. Leave blank
90	3/4" ASME BPE Tri-Clamp gauge fitting @ 90°
180	3/4" ASME BPE Tri-Clamp gauge fitting @ 180°
270	3/4" ASME BPE Tri-Clamp gauge fitting @ 270°

*Note: See Page 6 for Description of Gauge Ports

1 Body Finish	
A	20Ra (SFV5) Interior/40Ra Exterior (Std)
B	20Ra (SFV5) Interior/20Ra Exterior
C	8Ra Interior/40Ra Exterior*
D	20Ra (SFV5) Interior/8Ra Exterior
E	8Ra Interior/8Ra Exterior*
F	8Ra Interior/20Ra Exterior*

* Handle and all external surfaces meet spec per above. The adjusting screw is a threaded part and cannot be polished beyond 20Ra

2 Body Cv (Kv) See chart on page 2		
	Cv	Kv
A	1.5	1,3
D	2.5	2,2
H	4.5	3,9
K	5.5 & 6.1	4,7 & 5,3
M	10.0	8,6
N	19.0	16,3
P	23.0	19,8

3 Trim Finish	
A	20Ra (Standard)
B	8Ra

4 Trim - Cv (Kv) & Seat			
A	1.5 (1,3) Hard Seat	N	5.5 (4,7) Jorlon Seat
2	1.5 (1,3) Jorlon Seat	P	10 (8,6) Hard Seat
B	2.5 (2,2) Hard Seat	Q	10 (8,6) Teflon Seat
C	2.5 (2,2) Teflon Seat	R	10 (8,6) Jorlon Seat
D	2.5 (2,2) Jorlon Seat	S	19 (16,3) Hard Seat
H	4.5 (3,9) Hard Seat	T	19 (16,3) Teflon Seat
J	4.5 (3,9) Teflon Seat	U	19 (16,3) Jorlon Seat
K	4.5 (3,9) Jorlon Seat	V	23 (19,8) Hard Seat
L	5.5 (4,7) Hard Seat	W	23 (19,8) Teflon Seat
M	5.5 (4,7) Teflon Seat	X	23 (19,8) Jorlon Seat
7	6.1 (5,3) Hard Seat		

5 & 6 O-Ring/Diaphragm	
BU	Buna-N/SST Diaphragm
EE	EPDM/EPDM Diaphragm
EP	EPDM/SST Diaphragm
SL	Silicone/SST Diaphragm
TS	Teflon Encaps. Silicone/SST Diaphragm (1" - 3" only)*
TY	Teflon Encaps. Viton/Jorlon Diaphragm
TV	Teflon Encaps. Viton/SST Diaphragm
VT	Viton/SST Diaphragm

* See note on Page 2

7 Adjusting Screw Finish (Except Threads)	
A	Electro-polished (Standard)
B	20Ra (SFV5)
C	8Ra

8 Range PSI (Bar) see chart on page 2	
A	3 - 8 (0,2 - 0,6)*
C	5 - 25 (0,3 - 1,7)
E	10 - 25 (0,7 - 1,7)
P	15 - 25 (1,0 - 1,7)
H	15 - 50 (1,0 - 3,4)
J	15 - 60 (1,0 - 4,1)
M	35 - 100 (2,4 - 6,9)
R	40 - 90 (2,8 - 6,2)
T	75 - 135 (5,2 - 9,3)

* Must use EPDM or Ultra-thin Jorlon diaphragm

9 & 10 Diaphragm	
6L	SST (all exterior)
EP	EPDM (all exterior)
JL	Jorlon (all exterior)
UJ	Ultra-thin Jorlon (all exterior)

11 & 12 Actuator Finish/Type	
AA	Standard
BA	20Ra (SFV5) exterior
CA	8Ra exterior
DA	Electro-polished for 2" & 3"

13 & 14 PED Compliance	
00	Not required
0G	SEP (3/4" - 1")
0F	CE Category 1 (1-1/2", 2", 3")