

Mark 96A Series

CRN Registration Number Available

Sanitary Air Loaded Pressure Regulators

The Mark 96A is an air loaded sanitary pressure reducing valve designed to permit the user to change setpoints remotely via a cabinet or panel mounted air regulator, or through a distributed control system using an I-P transducer.

The Mark 96A is an ideal choice for automating the SIP/CIP process when the operating setpoint for each operation is different. With remote setpoint change capability, the valve pressure can be changed by remotely adjusting the air pressure loaded to the dome to the unique needs of the current operation.

FEATURES

- CRN Registration Number Available
- Air-loaded design significantly reduces size and weight and can minimize offset in some applications
- Optimized diaphragm material, surface area and support system for unsurpassed performance and life
- Valve sub-assembly same as time-tested MK96 design
- Permits automated CIP/SIP
- Available with extended range I-P transducer or a SST gas regulator

DOCUMENTATION

The following documentation is shipped with each order:

- Steriflow Unicert
 - Traceable Material Heat Number for body and ferrules
 - Certificate of Compliance to FDA and USP Class VI

Certificate of Surface Finish

- Final Test Reports and Certificate of Origin available upon request at time of order



APPLICATIONS

A wide variety of applications exist for the MK96A in the pharmaceutical, biotech, health-care, food & beverage and other industries including:

- Clean Steam
- WFI
- Process Gases
- Clean Filtered Air
- CIP Chemicals
- Food/Beverage Product
- Pharmaceutical Product
- Biochemicals

SPECIFICATIONS

Sizes: 1" (DN25), 1-1/2" (DN40), 2" (DN50)

Material: 316L Barstock body and trim

End Connections: ASME Tri-Clamp, butt weld, others consult factory

Cv:

- 4.5 (1")
- 10 (1-1/2")
- 19 (2")

Seat Material: Teflon® (FDA, USP CL 6 approved), PEEK (FDA, USP CL 6 approved) optional

Shutoff: ANSI Class VI

Actuator Housing: Air-loaded, clear coat anodized aluminum housing (standard) or electropolished 316 Stainless Steel (optional)

O-Ring Material: FDA, USP CL 6 approved Teflon-Encapsulated Viton

Diaphragm Material: Jorlon (FDA, USP CL 6 approved)

Maximum Setpoint: 100 psi (6,9 bar) – see operational chart

Maximum Operating Pressure @ Maximum Temperature: 200 psi @ 300°F (13,8 bar @ 149°C)

Maximum Pressure Drop: up to 100 psi (6,9 bar) – see operational chart

Maximum Air Supply Pressure: 110 psi

Weight:

- 1" – 12.0 lbs (5,4 kgs) – Aluminum
- 1" – 12.5 lbs (5,7 kgs) – Stainless Steel
- 1-1/2" – 31.0 lbs (14,1 kgs) – Aluminum
- 1-1/2" – 34 lbs (15,4 kgs) – Stainless Steel
- 2" – 69 lbs (31,3 kgs) – Aluminum
- 2" – 72 lbs (32,7 kgs) – Stainless Steel

DIMENSIONS

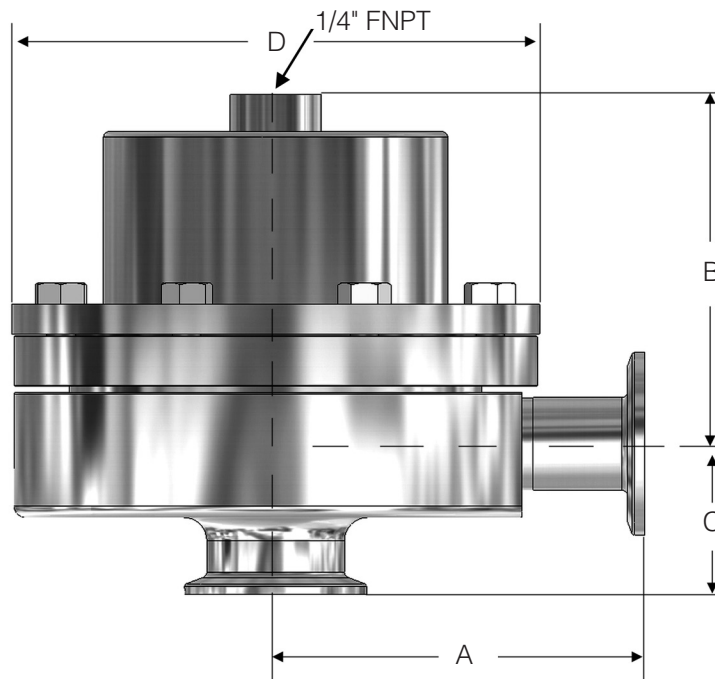

Valve Size	Dimensions (inches)			
	A	B	C	D
1"	4.00	3.80	1.64	5.75
1-1/2"	4.21	6.40	2.53	7.22
2"	5.34	6.75	2.96	9.50

Valve Size	Dimensions (mm)			
	A	B	C	D
DN25	101,6	96,5	41,7	146,1
DN40	106,9	162,6	64,3	183,4
DN50	135,6	171,5	75,2	241,3

Based on US tri-clamp ends. Consult factory for DIN and ISO tri-clamp end dimensions

AVAILABLE FINISHES

Body

- Standard: 20 Ra μin (0,5 Ra μm) (ASME BPE 2014 SF5) mechanical finish and electropolish on inside wetted surfaces; machine finish and electropolish on exterior.
- Optional: 20 Ra μin (0,5 Ra μm) SF5 mechanical finish and electropolish on external surfaces; 8 Ra μin (0,2 Ra μm) finish on internal or external finishes and electropolish (Better than SF4)

Bonnet Dome

- Standard: 20 Ra μin (0,5 Ra μm) machine finished and electropolished 316SST. If aluminum, not electropolished
- Optional: 20 Ra μin (0,5 Ra μm) mechanical finish and electropolish on external surfaces (SF5). 8 Ra μin (0,2 Ra μm) finish on external surfaces on all sizes and electropolish. (Better than SF4). If aluminum, not electropolished

MARK 96A SERIES CUT-A-WAY

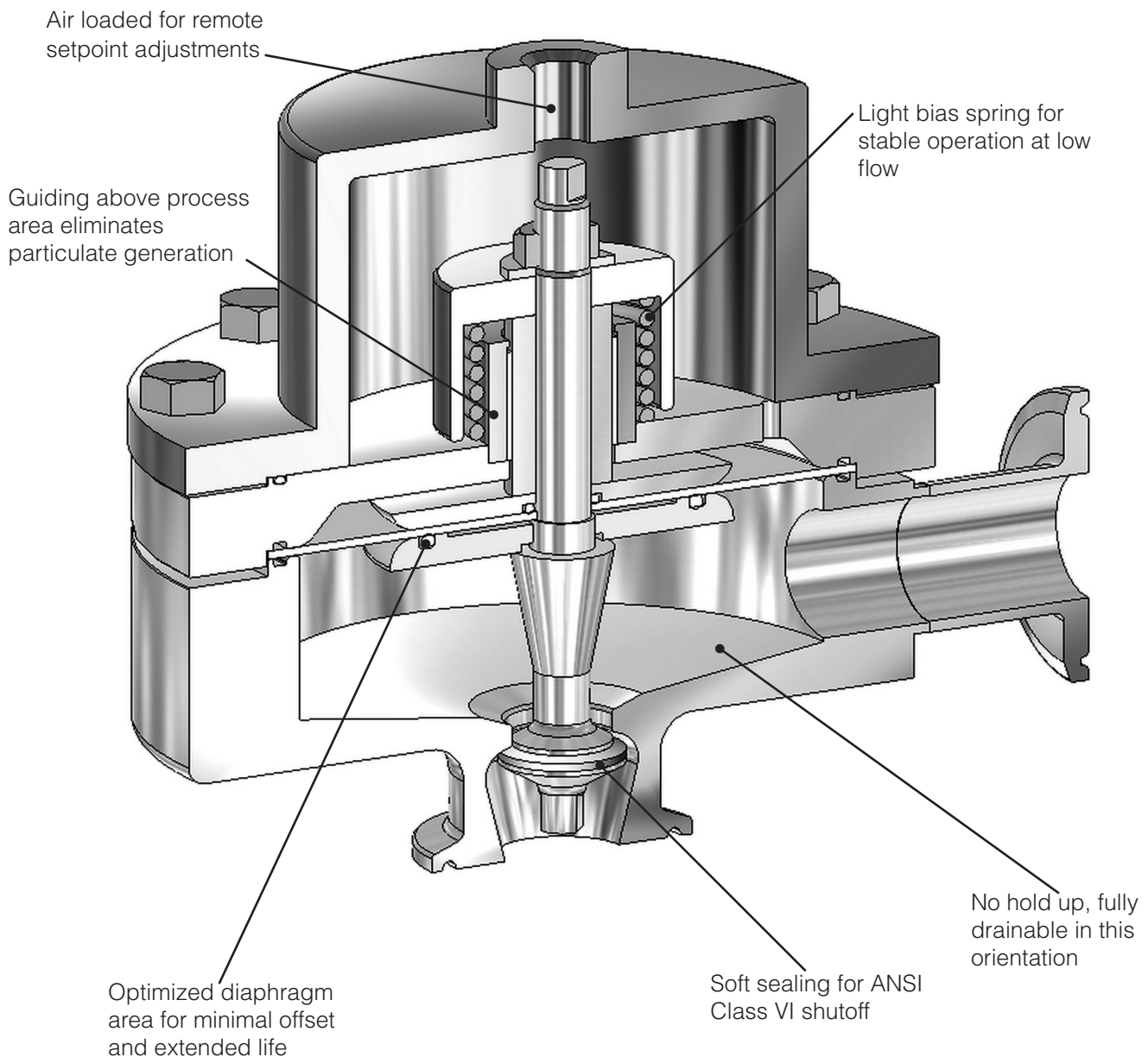

MAXIMUM INLET PRESSURE VS SETPOINT

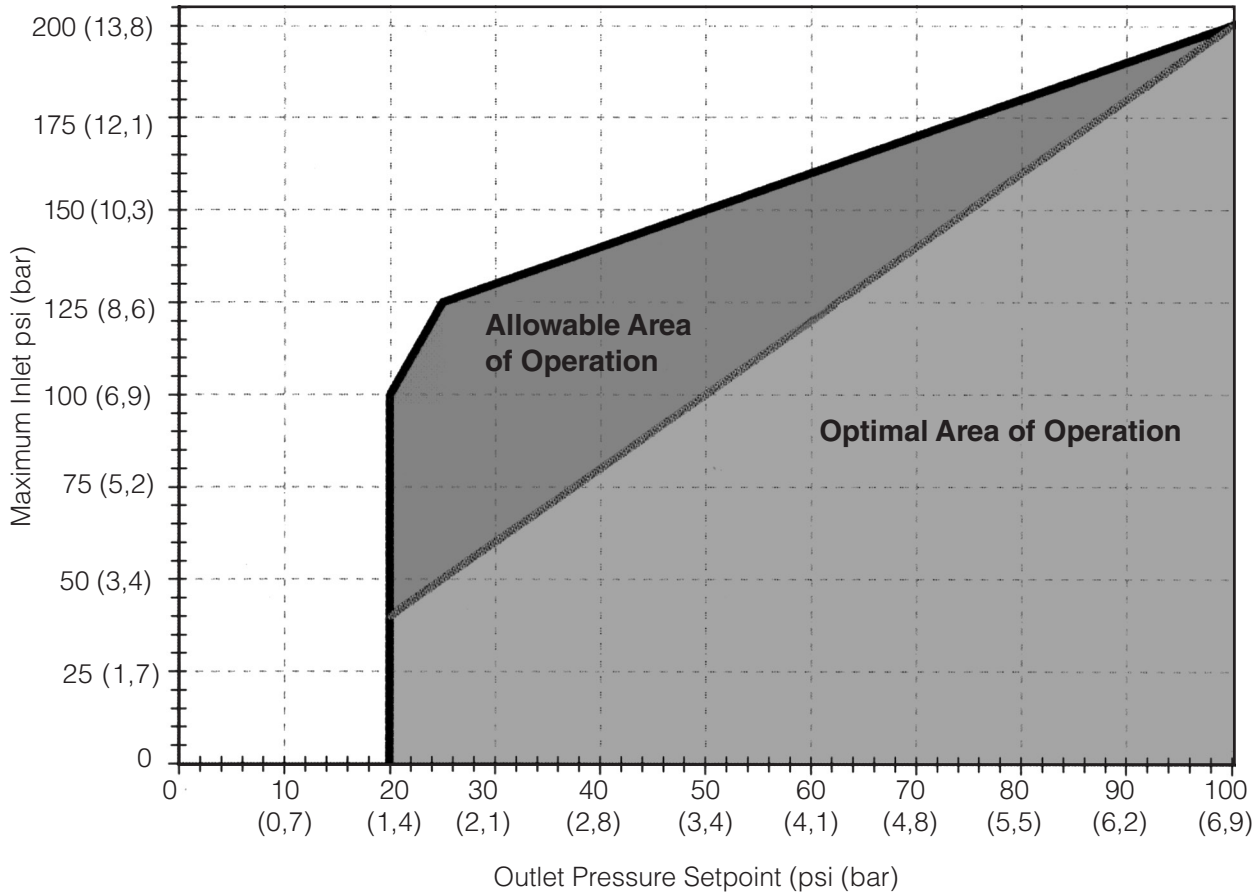

Determining Allowable & Optimal Setpoint

Reading the graph: To determine allowable setpoint select your inlet pressure from the Y-axis on the above graph. Outlet pressure setpoint should be equal to or greater than the value on the X-axis where the inlet pressure and heavy diagonal line intersect. In other words, the differential pressure (between inlet pressure and outlet pressure setpoint) must be less than or equal to 100 psi. In addition the minimum outlet pressure setpoint is 20 psig.

For optimal results (minimum offset, more stability) the ratio of inlet pressure to the outlet pressure setpoint (differential pressure) should be 2:1 or less, and never greater than 100 psig. For example, if the inlet pressure is 150 psi, the allowable outlet pressure setpoint would be 50 psi or above. However, the optimal outlet pressure setpoint (greater stability and less droop) is 75 psig or greater.

Note:

1. Valve actuator loading pressure (supply pressure) must be at least 3 psi above the desired outlet pressure setpoint. This is needed to overcome the return spring bias.

Installation Notes

- As with all regulators and control valves, optimal flow performance can only be achieved with a non-turbulent flow profile. The Mark 96A should be installed with 3 feet of straight pipe on either side of the valve.
- A pressure gauge, or transmitter reading downstream of the Mark 96A should be used to make the final setpoint adjustment.

% STROKE VS FLOW (1" MK96A – JORLON DIAPHRAGM – 4.5 Cv)

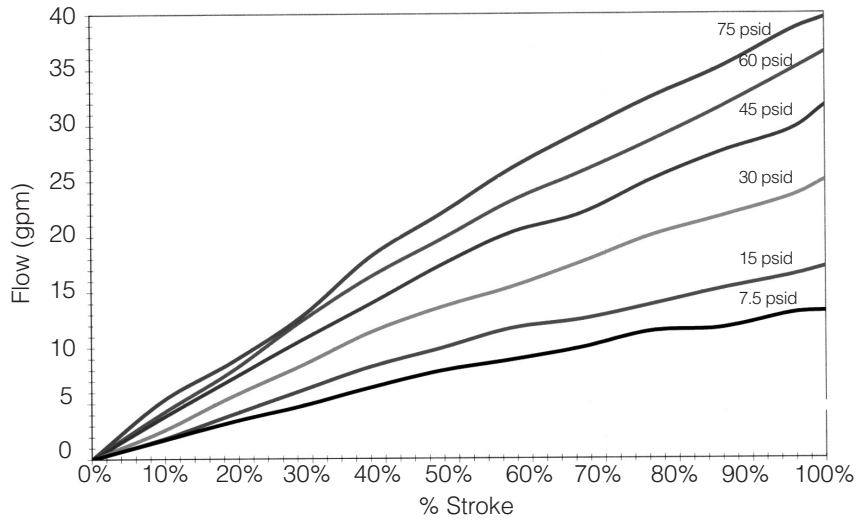

% STROKE VS FLOW (1-1/2" MK96A – JORLON DIAPHRAGM – 10 Cv)

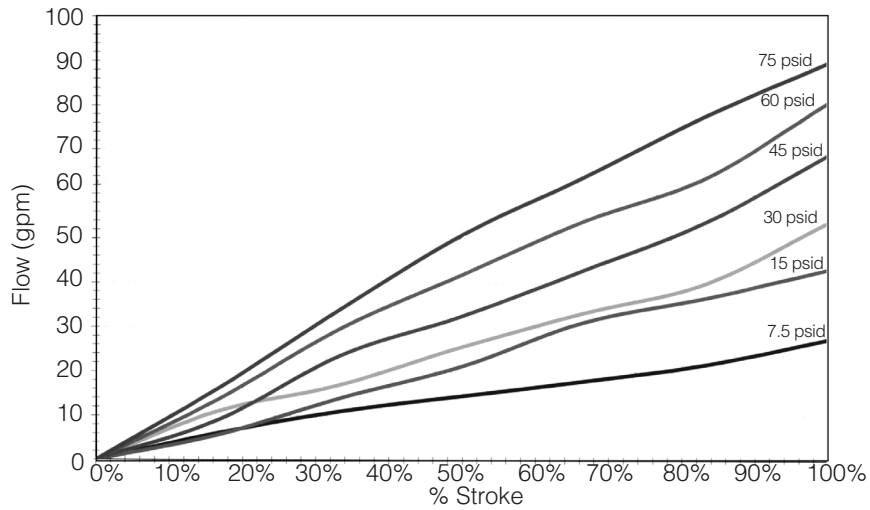

% STROKE VS FLOW (1-1/2" MK96A – JORLON DIAPHRAGM – 19 Cv)

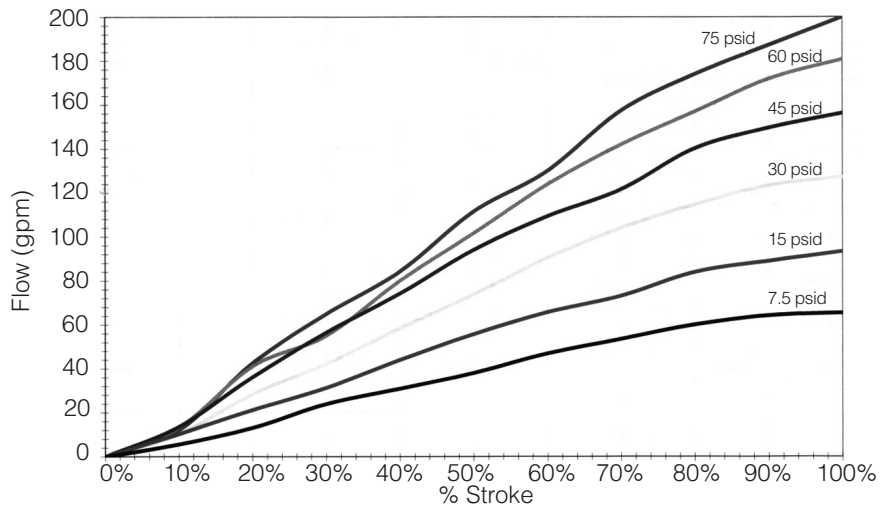

ORDER SCHEMATIC

1	—	2	—	3	/	4	5	6	7	8	9
---	---	---	---	---	---	---	---	---	---	---	---

1	Model	
96A	Standard	

2	Size	
100	1" (DN25)	
150	1-1/2" (DN40)	
200	2" (DN50)	

3	Material	
6L	316L Stainless Steel	

4	Body & Cv	
AH	20ra Interior/63rms Exterior (Standard); 4.5Cv	
BH	20rA Interior/20ra Exterior; 4.5Cv	
CH	8rA Interior/63rms Exterior; 4.5Cv	
DH	20rA Interior/8ra Exterior; 4.5Cv	
EH	8rA Interior/8ra Exterior; 4.5Cv	
FH	8rA Interior/20ra Exterior; 4.5Cv	
AM	20rA Interior/63rms Exterior (Standard); 10Cv	
BM	20rA Interior/20ra Exterior; 10Cv	
CM	8rA Interior/63rms Exterior; 10Cv	
DM	20rA Interior/8ra Exterior; 10Cv	
EM	8rA Interior/8ra Exterior; 10Cv	
FM	8rA Interior/20ra Exterior; 10Cv	
AN	20rA Interior/63rms Exterior (Standard); 19Cv	
BN	20rA Interior/20ra Exterior; 19Cv	
CN	8rA Interior/63rms Exterior; 19Cv	
DN	20rA Interior/8ra Exterior; 19Cv	
EN	8rA Interior/8ra Exterior; 19Cv	
FN	8rA Interior/20ra Exterior; 19Cv	
ZZ	Non-Standard	

5	Trim; Cv & Seat	
AJ	20 rA (Standard); Cv 4.5 Teflon Seats	
BJ	8 rA; Cv 4.5 Teflon Seats	
AQ	20 rA (Standard); Cv 10 Teflon Seats	
BQ	8 rA; Cv 10 Teflon Seats	
AT	20 rA (Standard); Cv 19 Teflon Seats	
BT	8 rA; Cv 19 Teflon Seats	

6	O-Ring	
TY	Teflon Encaps. Viton / Jorlon Diaphragm	
ZZ	Non-Standard	

7	I/P or Loader Range	
	Type of Loader Max Load (psi)	
00	None	
AP	60 psi output I/P	
AH	120 psi output I/P	
BA	JSRLF Series 25 psi output*	
BC	JSRLF Series 50 psi output*	
BE	JSRLF Series 100 psi output*	

*JSRLF or JSRLF (Teflon or EPDM seat) with 1/4" FNPT connection and self relieving feature must be ordered.

8	Diaphragm	
JL	Jorlon	

9	Actuator	
AA	Anodized Aluminum	
BA	316 Stainless Steel	

10	Accessories	
SC	Clean for oil free	
XC	O2 Clean	
OF	PED Certification	



Steriflow, a division of Jordan Valve
 3170 Wasson Road • Cincinnati, OH 45209
 513.533.5600 • 800.543.7311 • 513.871.0105 (f)
 steriflow@richardsind.com • www.steriflowvalve.com

Steriflow Valve reserves the right to make revisions to its product, specifications, literature and related information without notice. Please visit our website at www.steriflowvalve.com for the latest information on our products.